

# Service Manual

QUARTZ Synthesizer FM/AM Stereo Tuner

## ST-8

[EX], [EH], [XA], [XL]

## ST-8(K)

[EX], [EH], [XA], [XL], [XM]



- \* The colors of this model include silver and black.
- \* The black type model is provided with (K) in the Service Manual.

### Areas

- \* [EX] is available in Switzerland and Scandinavia.
- \* [EH] is available in Holland.
- \* [XA] is available in Southeast Asia, Oceania, Africa, Middle Near East and Central South America.
- \* [XL] is available in Australia.
- \* [XM] is available in Mexico.

## Specifications (Specifications are subject to change without notice for further improvement.)

### (DIN 45 500)

#### ■ FM TUNER SECTION

Frequency range	87.50~108.00 MHz
Sensitivity	
S/N 30 dB	1.0 $\mu$ V (75 $\Omega$ )
S/N 26 dB	0.9 $\mu$ V (75 $\Omega$ )
S/N 20 dB	0.8 $\mu$ V (75 $\Omega$ )
IHF 46 dB stereo quieting sensitivity	22.0 $\mu$ V/75 $\Omega$
Total harmonic distortion	
MONO	0.08%
STEREO	0.15%
S/N	
MONO	70 dB (78 dB, IHF)
STEREO	65 dB (73 dB, IHF)
Frequency response	20 Hz~15 kHz, +0.5 dB~-1.5 dB
Alternate channel selectivity	
normal $\pm$ 400 kHz	65 dB
Capture ratio	1.0 dB
Image rejection at 98 MHz	55 dB
IF rejection at 98 MHz	80 dB
Spurious response rejection at 98 MHz	80 dB
AM suppression	55 dB
Stereo separation	
1 kHz	40 dB
10 kHz	30 dB
Carrier leak	
19 kHz	-30 dB (-35 dB, IHF)
38 kHz	-45 dB (-50 dB, IHF)
Channel balance (250 Hz~6,300 Hz)	$\pm$ 1.0 dB

Limiting point	1.9 $\mu$ V
Bandwidth	
IF amplifier	180 kHz
FM demodulator	1000 kHz
Antenna terminals	75 $\Omega$ (unbalanced)

#### ■ AM TUNER SECTION

Frequency range	(For [XA] area)	[ 531~ 1620kHz (9kHz step) ]
		[ 530~ 1620kHz (10kHz step) ]
	(For others)	[ 522~ 1611kHz (9kHz step) ]
		[ 530~ 1620kHz (10kHz step) ]
Sensitivity (S/N 20 dB)		20 $\mu$ V, 300 $\mu$ V/m
Selectivity ( $\pm$ 9 kHz)		55 dB
Image rejection at 999 kHz		40 dB
IF rejection at 999 kHz		65 dB

#### ■ GENERAL

Output voltage	0.3V
Power consumption	9W
Power supply	
(For continental Europe)	AC 50 Hz/60 Hz, 220V
(For others)	AC 50 Hz/60 Hz, 110V/120V/220V/240V
(For Australia)	AC 50 Hz/60 Hz, 240V
Dimensions (W×H×D)	315 × 50 × 244 mm
	(12-13/32" × 1-31/32" × 9-19/32")
Weight	2.0 kg
	(4.4 lb.)

# Technics

Matsushita Electric Trading Co., Ltd.  
P.O. Box 288, Central Osaka Japan

## CONTENTS

	Page		Page
SAFETY PRECAUTION . . . . .	2	RESISTORS AND CAPACITORS . . . . .	13
AM LOOP ANTENNA . . . . .	2	FUNCTION OF TERMINAL ( PLL CONTROLLER IC901 ) . . . . .	14,15
LOCATION OF CONTROLS . . . . .	3	TERMINAL FUNCTION OF DIRECT CONNECTOR . . . . .	15
CONNECTION TO AMPLIFIER . . . . .	3	BLOCK DIAGRAM . . . . .	16 ~ 18
HOW TO OPERATE . . . . .	4,5	SCHEMATIC DIAGRAM . . . . .	19 ~ 21
BEFORE REPAIR . . . . .	5	REPLACEMENT PARTS LIST . . . . .	22,23
DISASSEMBLY INSTRUCTIONS . . . . .	6 ~ 8	EXPLODED VIEW . . . . .	23,24
MEASUREMENTS AND ADJUSTMENTS . . . . .	9,10		
CIRCUIT BOARD AND WIRING CONNECTION DIAGRAM . . . . .	11,12		

## SAFETY PRECAUTION

1. Before servicing, unplug the power cord to prevent an electric shock.
2. When replacing parts, use only manufacturer's recommended components for safety.
3. Check the condition of the power cord. Replace if wear or damage is evident.
4. After servicing, be sure to restore the lead dress, insulation barriers, insulation papers, shields, etc.
5. Before returning the serviced equipment to the customer, be sure to make the following insulation resistance test to prevent the customer from being exposed to a shock hazard.

### INSULATION RESISTANCE TEST

1. Unplug the power cord and short the two prongs of the plug with a jumper wire.
2. Turn on the power switch.
3. Measure the resistance value with ohmmeter between the jumpered AC plug and each exposed metal cabinet part, such as screwheads antenna, control shafts, handle brackets, etc. Equipment with antenna terminals should read between  $3M\Omega$  and  $5.2M\Omega$  to all exposed parts. (Fig. A) Equipment without antenna terminals should read approximately infinity to all exposed parts. (Fig. B)

**Note:** Some exposed parts may be isolated from the chassis by design. These will read infinity.

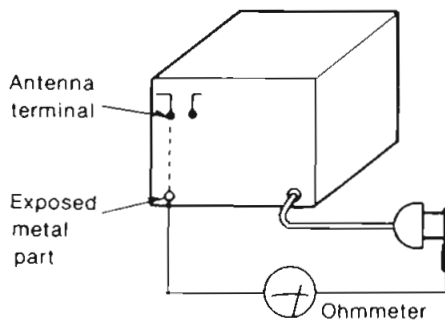

(Fig. A)

Resistance =  $3M\Omega$ — $5.2M\Omega$

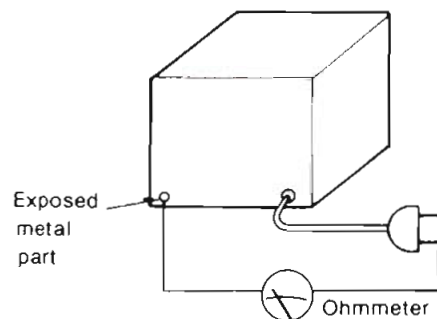

(Fig. B)

Resistance = Approx  $\infty$

4. If the measurement is outside the specified limits, there is a possibility of a shock hazard. The equipment should be repaired and rechecked before it is returned to the customer.

## AM LOOP ANTENNA

When the AM loop antenna is connected to the rear panel, place it as far away from the set as possible to improve the sensitivity.

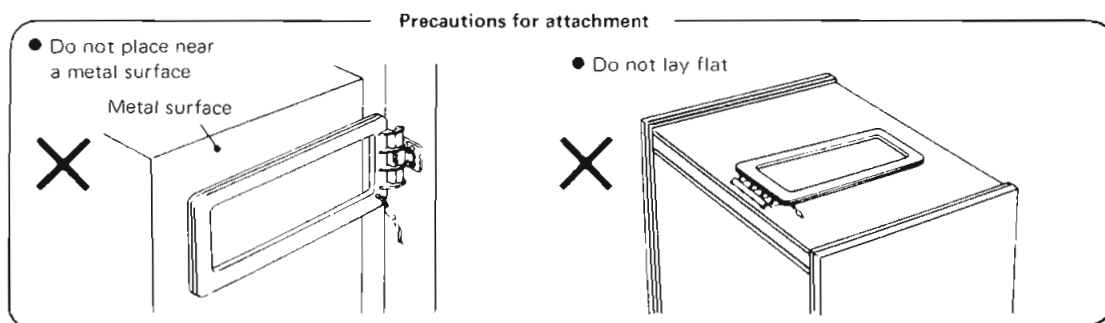

- This booklet includes the specifications and adjustment of Model ST-8 (Order No. HAD83122671C8) written in German, French and Spanish.
- File this booklet together with the service manual of Model ST-8.
- Dieses Büchlein umfaßt die technischen Daten und Justierungsanleitungen von Modell ST-8 (Bestell Nr. HAD83122671C8) in den Sprachen Deutsch, Französisch und Spanisch.
- Bewahren Sie dieses Büchlein zusammen mit dem Service-Handbuch von Modell ST-8 auf.
- Cette brochure comprend les spécifications et la mise au point du Modèle ST-8 (N<sup>o</sup> d'Ordre HAD83122671C8) écrites en allenmand, en francais et en espagnol.
- Classer cette brochure en meme temps qu'avec le manuel de service du Modele ST-8.
- Este librito incluye las especificaciones y ajuste de Modelo ST-8 (Pedido N<sup>o</sup> HAD83122671C8) escritas en alemán, francés y español.
- Guardar este librito juntamente con el manual servicio de Modelo ST-8.

## DEUTSCH

### ■ TECHNISCHE DATEN (Die technischen Daten können infolge von Verbesserungen ohne Ankündigung geändert werden.)

#### (DIN 45 500)

##### ■ UKW-TUNERTEIL

<b>Wellenbereich</b>	87,50 ~ 108,00 MHz
<b>Eingangsempfindlichkeit</b>	
S/R 30 dB	1,0 $\mu$ V (75 $\Omega$ )
S/R 26 dB	0,9 $\mu$ V (75 $\Omega$ )
S/R 20 dB	0,8 $\mu$ V (75 $\Omega$ )
<b>Stereoschaltsschwelle bei 46 dB nach IHF</b>	22,0 $\mu$ V/75 $\Omega$
<b>Gesamtklirrfaktor</b>	
Mono	0,08%
Stereo	0,15%
<b>Geräuschabstand</b>	
Mono	70 dB (78 dB nach IHF)
Stereo	65 dB (73 dB nach IHF)
<b>Frequenzgang</b>	20 Hz ~ 15 kHz, +0,5 dB ~ -1,5 dB
<b>Trennschärfe bei Störsender</b>	
normal $\pm$ 400 kHz	65 dB
<b>Einfangverhältnis</b>	1,0 dB
<b>Spiegelfrequenz-Dämpfung bei 98 MHz</b>	55 dB
<b>ZF-Dämpfung bei 98 MHz</b>	80 dB
<b>Ansprechdämpfung auf Nebenfrequenzen bei 98 MHz</b>	80 dB
<b>AM-Unterdrückung</b>	55 dB
<b>Übersprechdämpfung</b>	
1 kHz	40 dB
10 kHz	30 dB
<b>Trägerrest</b>	
19 kHz	-30 dB (-35 dB nach IHF)
38 kHz	-45 dB (-50 dB nach IHF)
<b>Kanalabweichung (250 Hz ~ 6300 Hz)</b>	$\pm$ 1,0 dB
<b>Begrenzereinsatz</b>	1,9 $\mu$ V

<b>Bandbreite</b>	
ZF-Verstärker	180 kHz
UKW-Demodulator	1000 kHz
<b>Antennenanschluß</b>	75 $\Omega$ (unsymmetrisch)

##### ■ AM-TUNERTEIL

<b>Wellenbereiche</b>	522 ~ 1611 kHz (9-kHz Schritte) 530 ~ 1620 kHz (10-kHz Schritte)
<b>Eingangsempfindlichkeit (S/R 20 dB)</b>	20 $\mu$ V, 300 $\mu$ V/m
<b>Trennschärfe (<math>\pm</math>9 kHz)</b>	55 dB
<b>Spiegelfrequenz-Dämpfung bei 999 kHz</b>	40 dB
<b>ZF-Dämpfung bei 999 kHz</b>	65 dB

##### ■ ALLGEMEINE DATEN

<b>Ausgangsspannung</b>	0,3V
<b>Leistungsaufnahme</b>	9W
<b>Netzspannung</b>	
(Für Kontinentaleuropa)	Wechselstrom 50 Hz/60 Hz, 220V
(Für andere Länder)	Wechselstrom 50 Hz/60 Hz, 110V/120V/220V/240V
<b>Abmessungen (B×H×T)</b>	315 × 50 × 244 mm
<b>Gewicht</b>	2,0 kg

## ■ MESSUNGEN UND JUSTIERUNGEN

Anmerkung: Die AM-OSC-Spule (L203) und AM ZFT (T201) sind bereits justiert und benötigt daher keine Justierung.

### AM (MW)-EINSTELLUNG

• **Stellungen und zu benutzende Geräte**

- |   |  |
|---|--|
| <ol style="list-style-type: none"> <li>1. Elektronisches Voltmeter für Wechselstrom (VTVM).</li> <li>2. AM (MW)-Meßsender (AM-SG).</li> <li>3. Bereichsschalter, . . . . . AM</li> <li>4. AM (MW) Wellenverteilungs-Wahlschalter auf Position "9 kHz" stellen.</li> </ol> | <ol style="list-style-type: none"> <li>5. Netzspannung auf ihrem Sollwert halten.</li> <li>6. Der Ausgang des Meßsenders darf nicht höher sein als unbedingt notwendig für eine gute Ablesung.</li> <li>7. Einen nichtmetallischen Schraubenzieher für die Einstellungen verwenden.</li> </ol> |
|---|--|

AM (MW)-MESSENDER		ANZEIGE-FREQUENZ DURCH VOR-EINSTELLUNG	VORBEREITUNG	ABGLEICHSPUNKTE	ABGLEICHVERFAHREN	
ANSCHLUSS	FREQUENZ					
<b>AM (MW)-HF-ABGLEICH</b>						
1	AM-MO über 200 pF Kondensator an den AM-Antennenanschluß anschließen, wie in Abb. 11 gezeigt.	612 kHz (400 Hz Modulat., 30%)	612 kHz	Wechselstrom-Voltmeter oder Oszillograph über den Ausgang "OUTPUT" anschließen.	L202 (Ant. Spule)	1. Auf max. Ausgang abgleichen. 2. Den Ferritkern von L202 mit einem Schraubendreher justieren.
	2	(Schwacher Eingang.)	1503 kHz (400 Hz Modulat., 30%)		1503 kHz	CT201 (Ant. Trimmer)

### FM (UKW)-EINSTELLUNG

• **Stellungen und zu benutzenden Geräte**

1. UKW-Meßsender (FM-SG)
2. Klirrfaktor-Meßbrücke.
3. Oszillograph.
4. Elektronische Voltmeter für Wechsel- und Gleichstrom (VTVM).
5. Signalfrequenzmesser (meßbar für 19 kHz und 108 MHz)
6. Bereichsschalter, . . . . . FM
7. Den UKW-Betriebsartenschalter auf die "mono"-Position stellen.
8. Die anderen Einstellungen sind gleich wie beider MW-Justierung.

• **Vorbereitung des UKW-Meßoszillators (UKW-MO)**

Die Normal-Eingangsleistung dieses Gerätes beträgt 60 dB (1 mV), 400 Hz, 100% Modulation. (Wegen der Dämpfung bei Verwendung von Koaxialkabeln, muß die MO-Ausgangsleistung 6 dB oder mehr betragen; d.h. wenn die Eingangsleistung 60 dB beträgt, muß der MO-Ausgang 66 dB betragen.)

FM (UKW)-MESSENDER		ANZEIGE-FREQUENZ DURCH VOR-EINSTELLUNG	VORBEREITUNG	ABGLEICHSPUNKTE	ABGLEICHVERFAHREN	
ANSCHLUSS	FREQUENZ					
<b>ABGLEICH AUF MIN. VERZERRUNG IN STELLUNG UKW-MONO</b>						
3	UKW-MO an FM Antennende anschließen, wie in Abb. 12 gezeigt. (60 dB in den Antenneneingang anlegen.)	100,10 MHz (400 Hz Modulat. 100%)	100,10 MHz	Ein Gleichstrom-Voltmeter zwischen <b>TP101</b> (-) und <b>TP102</b> (+) über eine Drossel-spule anschließen.	T101 (Diskriminator FT)	Den Kern von T101 so justieren, daß die gemessene Spannung im signallosen Zustand 0 mV im 300 mV Bereich beträgt.
				Klirrfaktor-Meßbrücke an Ausgangsklemme "OUTPUT" anschließen.	T102 (Diskriminator FT)	Kern von T102 für minimale Verzerrung der rechten und linken Kanäle justieren.
<b>UKW-STEREO-DEKODER-ABGLEICH</b>						
UNTER VERWENDUNG EINES ZÄHLERS			ALTERNATIV-MESSMETHODE			
5	1. Unmoduliertes Mono-Signal 100,10 MHz in das Gerät speisen. 2. FM mode-Schalter auf "FM auto" stellen. 3. Zähler über einen Widerstand von 100k Ohm an <b>TP301</b> anschließen, (Vgl. Abb.13) 4. <b>VR301</b> auf 19 kHz ± 30 Hz einstellen.			1. Stereosignal entweder von einem Stereogenerator, oder einem Sender einspeisen. 2. <b>VR301</b> so einstellen, bis die Stereolampe aufleuchtet. Schleifer von <b>VR301</b> sichern, wie in Abb. 14 gezeigt.		

# FRANÇAIS

## ■ CARACTERISTIQUES (Sujet à changement sans avertissement préalable.)

(DIN 45 500)

### ■ SECTION SYNTONISATEUR FM

Gamme de fréquence	87,50~108,00 MHz
Sensibilité	
S/B 30 dB	1,0 $\mu$ V (75 $\Omega$ )
S/B 26 dB	0,9 $\mu$ V (75 $\Omega$ )
S/B 20 dB	0,8 $\mu$ V (75 $\Omega$ )
Sensibilité stéréo au seuil de 46 dB, IHF	22,0 $\mu$ V/75 $\Omega$
Distorsion harmonique totale	
MONO	0,08%
STEREO	0,15%
Signal/Bruit	
MONO	70 dB (78 dB, IHF)
STEREO	65 dB (73 dB, IHF)
Réponse de fréquence	20 Hz~15 kHz, +0,5 dB~ -1,5 dB
Sélectivité alternée par canal	
normal $\pm$ 400 kHz	65 dB
Taux de capture	1,0 dB
Rejection d'image à 98 MHz	55 dB
Rejection FI à 98 MHz	80 dB
Rejection de réponse parasite à 98 MHz	80 dB
Suppression AM	55 dB
Séparation stéréophonique	
1 kHz	40 dB
10 kHz	30 dB
Fuite de porteuse	
19 kHz	-30 dB (-35 dB, IHF)
38 kHz	-45 dB (-50 dB, IHF)
Equilibrage de canaux (250 Hz~6.300 Hz)	$\pm$ 1,0 dB

Point de limite	1,9 $\mu$ V
Largeur de bande	
Amplificateur FI	180 kHz
Démodulateur FM	1000 kHz
Bornes d'antenne	75 $\Omega$ (asymétrique)

### ■ SECTION SYNTONISATEUR AM

Gamme de fréquence	522~1611 kHz (9 kHz par palier) 530~1620 kHz (10 kHz par palier)
Sensibilité (S/B 20 dB)	20 $\mu$ V, 300 $\mu$ V/m
Sélectivité ( $\pm$ 9 kHz)	55 dB
Réjection d'image à 999 kHz	40 dB
Réjection FI à 999 kHz	65 dB

### ■ DIVERS

Tension de sortie	0,3V
Consommation	9W
Alimentation	
(Pour l'Europe)	CA 50 Hz/60 Hz, 220V
(Autres)	CA 50 Hz/60 Hz, 110V/120V/220V/240V
Dimensions (LxHxPr)	315 x 50 x 244 mm
Poids	2,0 kg

## REGLAGE DE FM

- **Réglage et équipement utilisé**
  - Générateur de signaux FM (FM-SG)
  - Commande de réglage stéréophonique (ou vu-mètre de séparation).
  - Eralonneur de distorsion.
  - Oscilloscope.
  - Voltmètres électronique de courant alternatif et de courant continu (VTVM).
  - Compteur de fréquence (19 kHz et 108 MHz mesurable).
  - Sélecteur d'entrée sur la position "FM".
  - Placer le sélecteur de mode FM sur la position "mono".
  - Les autres réglages sont les mêmes que pour la mise au point de l'amplitude modulée (AM).
- **Préparatifs pour le générateur de signaux FM (FM-SG).**
  - L'entrée normale de l'appareil est de 60 dB (1 mV), 400 Hz, modulation de 100%. (Du fait de l'atténuation, utiliser des câbles coaxiaux. La sortie du générateur de signaux devra être de plus de 6 dB. C'est-à-dire, que lorsque l'entrée est de 60 dB, la sortie du générateur de signaux devra être de 66 dB.)

GENERATEUR FM		FREQUENCE D'AFFICHAGE PAR PREREGLAGE	PREPARATIFS	ELEMENTS REGLES	PROCEDURE DE REGLAGE
BRANCHEMENT	FREQUENCE				
<b>RÉGLAGE DE LA DISTORSION FM EN MONO</b>					
N°					
3	Raccorder le générateur de signaux FM à la borne d'antenne FM, en se référant à la Fig. 12. (Niveau de sortie du générateur 60 dB.)	100,10 MHz (modulé à 100% par 400 Hz)	100,10 MHz	Brancher le voltmètre électronique à C.C. aux bornes <b>TP101</b> (-) et <b>TP102</b> (+)	T101 (Transfor. FI discri.) Régler le noyau T101 de telle sorte que le voltage mesuré dans le mode sans signal, soit de 0 mV dans la gamme des 300 mV.
4				Brancher un mesureur de distorsion sur les bornes de hautparleur de l'appareil.	T102 (Transfor. FI discri.) Régler le noyau T102 de telle sorte que la distorsion des canaux de droite et de gauche soit la plus faible.
<b>RÉGLAGE PILOTE MULTIPLEX FM</b>					
AVEC UN FRÉQUENCEMÈTRE			EN UTILISANT UN SYSTÈME ALTERNATIF		
5	1. Signal mono de 100,10 MHz 60 dB non modulé appliqué à l'appareil. 2. Commutateur de mode/accord silencieux FM sur "auto". 3. Branchez le fréquencemètre sur <b>TP301</b> par l'intermédiaire d'une résistance (100k $\Omega$ ). (Voir Fig. 13) 4. Régler <b>VR301</b> sur 19 kHz $\pm$ 30 Hz.			1. Appliquer un signal stéréophonique à l'appareil ou recevoir une émission stéréophonique. 2. Ajuster <b>VR301</b> et régler le contact à glissement de <b>VR301</b> au milieu de la plage en circuit de l'indicateur stéréophonique. (Voir Fig. 14)	

## ■ MESURAGES ET RÉGLAGES

Nota: La bobine oscillatrice de modulation d'amplitude (L203) et le transformateur de fréquence intermédiaire de modulation d'amplitude (T201) ont déjà été ajustée et ne nécessite pas de réglage.

### REGLAGE DE AM

- **Réglage et équipement utilisé**
  - Voltmètres électronique de courant alternatif et de courant continu (VTVM).
  - Générateur de signaux AM (AM-SG)
  - Sélecteur du gamme . . . . . AM
  - Régler le sélecteur d'attribution AM sur la position "9 kHz step".
  - Conserver la tension du secteur à la tension nominale.
  - Le signal du générateur ne doit pas être plus élevé qu'il n'est nécessaire à obtenir une lecture en sortie.
  - Utiliser un tournevis non-métallique pour le réglage.

GENERATEUR AM		FREQUENCE D'AFFICHAGE PAR PREREGLAGE	PREPARATIFS	ELEMENTS REGLES	PROCEDURE DE REGLAGE
BRANCHEMENT	FREQUENCE				
<b>RÉGLAGE DE IF-AM</b>					
N°					
1	Brancher le AM-SG à la borne de l'antenne AM par un condensateur de 200 pF. (Commun au châssis. (Eintée faible) (Se référer à la Fig. 11.)	612 kHz (modulé à 30% par 400 Hz)	612 kHz	C.A. voltmètre électronique ou oscilloscope sur prise de sortie de l'appareil.	L202 (Bobine Ant.) 1. Régler au maximum du signal de sortie. 2. Régler le noyau ferrite de L202 à l'aide d'un tournevis.
2		1503 kHz (Modulé à 30% par 400 Hz)	1503 kHz		CT201 (Trimmer Ant.) 1. Régler au maximum du signal de sortie. 2. Refaire les étapes (1) et (2) jusqu'à ce que le fréquence s'aligne correctement avec l'affichage du cadran.

ESPAÑOL

■ ESPECIFICACIONES

(Estas especificaciones están sujetas a cualquier cambio sin previo aviso.)

(DIN 45 500)

■ SECCION PARA SINTONIZADOR FM

Gama de frecuencias	87,50~108,00 MHz	Equilibrio de canales 250 Hz~6 300 Hz	±1,0 dB
Sensibilidad		Punto de límite	1,9 μV
Señal a ruido 30 dB	1,0 μV (75Ω)	Ancho de banda	
Señal a ruido 26 dB	0,9 μV (75Ω)	Amplificador FI	180 kHz
Señal a ruido 20 dB	0,8 μV (75Ω)	Demodulador FM	1000 kHz
Sensibilidad de acallamiento estéreo de 46 dB IHF	22,0 μV/75Ω	Bornes de antena	75Ω (no equilibrado)
Distorsión armónica total		<b>■ SECCION PARA SINTONIZADOR AM</b>	
MONO. (MONO)	0,08%	Gama de frecuencias	522~1611 kHz (9 kHz-step)
ESTEREO (STEREO)	0,15%		530~1620 kHz (10 kHz-step)
Relación de señal a ruido		Sensibilidad (Relación de señal a ruido de 20 dB)	20 μV, 300 μV/m
MONO. (MONO)	70 dB (78 dB, IHF)	Selectividad (±9 kHz)	55 dB
ESTEREO (STEREO)	65 dB (73 dB, IHF)	Rechazo de imagen a 999 kHz	40 dB
Respuesta de frecuencia	20 Hz~15 kHz, +0,5 dB~-1,5 dB	Rechazo de F.I. a 999 kHz	65 dB
Selectividad alternada de canal		<b>■ GENERAL</b>	
normal ±400 kHz	65 dB	Voltaje de salida	0,3V
Relación de captura	1,0 dB	Consumo de energía	9W
Rechazo de imagen a 98 MHz	55 dB	Requisito de energía	
Rechazo de F.I. a 98 MHz	80 dB	(Para Europa continental)	CA 50 Hz/60 Hz, 220V
Rechazo de respuesta espuria a 98 MHz	80 dB	(Para otros países)	CA 50 Hz/60 Hz, 110V/120V/220V/240V
Supresión AM	55 dB	Dimensiones (An.×Al.×Prof.)	315 × 50 × 244 mm
Separación estereofónica		Peso	2,0 kg
1 kHz	40 dB		
10 kHz	30 dB		
Fuga de onda portadora			
19 kHz	-30 dB (-35 dB, IHF)		
38 kHz	-45 dB (-50 dB, IHF)		

■ MEDICIONES Y AJUSTES

Nota: La bobina de OSC AM (L203) y AM IFT (T201) han sido ya ajustada y no requiere ajuste.

AJUSTE DE AM

<b>• Puesta y Uso de equipo</b>																														
1. Voltímetros electrónicos de CA (VTVM).		5. Mantener voltaje de línea a voltaje nominal.																												
2. Generador de señales AM (AM-SG).		6. La salida de generador de señales no debe ser mayor que la necesaria para obtener una lectura de salida.																												
3. Poner selector FM-AM en posición "AM".		7. Para el ajuste use un destornillador no metálico.																												
4. Poner selector de asignación AM en posición "9 kHz step".																														
<table border="1"> <thead> <tr> <th colspan="2">GENERADOR DE SEÑALES AM</th> <th rowspan="2">A FRECUENCIA DE PRESENTACION</th> <th rowspan="2">PREPARACIONES</th> <th rowspan="2">PIEZAS AJUSTADAS</th> <th rowspan="2">PROCEDIMIENTO DE AJUSTE</th> </tr> <tr> <th>CONEXION</th> <th>FRECUENCIA</th> </tr> </thead> <tbody> <tr> <td colspan="6" style="text-align: center;"><b>AJUSTE RF-AM</b></td> </tr> <tr> <td rowspan="2">1</td> <td>Conector AM-SG a terminal de antena AM a través de capacitor 200 pF. Común a chasis (Entrada débil) (Referir a la Fig. 11)</td> <td>612 kHz (Mod. 30% con 400 Hz)</td> <td>612 kHz</td> <td>L202 (Bobina ANT AM)</td> <td>1. Ajustar para salida máxima. 2. Ajustar núcleo de ferrita de L202 con destornillador.</td> </tr> <tr> <td></td> <td>1503 kHz (Mod. 30% con 400 Hz)</td> <td>1503 kHz</td> <td>CT201 (Trimer de ANT AM)</td> <td>1. Ajustar para salida máxima. 2. Repetir pasos (1) y (2) hasta que la frecuencia se adapte correctamente a la escala del cuadrante.</td> </tr> </tbody> </table>						GENERADOR DE SEÑALES AM		A FRECUENCIA DE PRESENTACION	PREPARACIONES	PIEZAS AJUSTADAS	PROCEDIMIENTO DE AJUSTE	CONEXION	FRECUENCIA	<b>AJUSTE RF-AM</b>						1	Conector AM-SG a terminal de antena AM a través de capacitor 200 pF. Común a chasis (Entrada débil) (Referir a la Fig. 11)	612 kHz (Mod. 30% con 400 Hz)	612 kHz	L202 (Bobina ANT AM)	1. Ajustar para salida máxima. 2. Ajustar núcleo de ferrita de L202 con destornillador.		1503 kHz (Mod. 30% con 400 Hz)	1503 kHz	CT201 (Trimer de ANT AM)	1. Ajustar para salida máxima. 2. Repetir pasos (1) y (2) hasta que la frecuencia se adapte correctamente a la escala del cuadrante.
GENERADOR DE SEÑALES AM		A FRECUENCIA DE PRESENTACION	PREPARACIONES	PIEZAS AJUSTADAS	PROCEDIMIENTO DE AJUSTE																									
CONEXION	FRECUENCIA																													
<b>AJUSTE RF-AM</b>																														
1	Conector AM-SG a terminal de antena AM a través de capacitor 200 pF. Común a chasis (Entrada débil) (Referir a la Fig. 11)	612 kHz (Mod. 30% con 400 Hz)	612 kHz	L202 (Bobina ANT AM)	1. Ajustar para salida máxima. 2. Ajustar núcleo de ferrita de L202 con destornillador.																									
		1503 kHz (Mod. 30% con 400 Hz)	1503 kHz	CT201 (Trimer de ANT AM)	1. Ajustar para salida máxima. 2. Repetir pasos (1) y (2) hasta que la frecuencia se adapte correctamente a la escala del cuadrante.																									

AJUSTE DE FM

<b>• Equipo usado</b>		<b>• Preparación de generador de señales FM (FM-SG)</b>																																																													
1. Generador de señales FM (FM-SG).		1. La entrada standard del aparato es 60 dB (1 mV), 400 Hz, modulación 100% (debido a atenuación, usando cables coaxiales. La salida SG ha de ser 6 dB más. Es decir, cuando la entrada es 60 dB, la salida de SG ha de ser 66 dB.)																																																													
2. Modulador estereofónico (o medidor de separación).																																																															
3. Analizador de distorsión.																																																															
4. Osciloscopio.																																																															
5. Voltímetros electrónicos de CA y CC (VTVM).																																																															
6. Frecuencímetro (19 kHz y 108 MHz medibles).																																																															
7. Poner selector FM-AM en posición "FM".																																																															
8. Poner el interruptor de modalidad FM en la posición "MONO".																																																															
9. Otras puestas son las mismas que en ajuste AM.																																																															
<table border="1"> <thead> <tr> <th rowspan="2">Nº.</th> <th colspan="2">GENERADOR DE SEÑALES FM</th> <th rowspan="2">A FRECUENCIA DE PRESENTACION</th> <th rowspan="2">PREPARACIONES</th> <th rowspan="2">PIEZAS AJUSTADAS</th> <th rowspan="2">PROCEDIMIENTO DE AJUSTE</th> </tr> <tr> <th>CONEXION</th> <th>FRECUENCIA</th> </tr> </thead> <tbody> <tr> <td colspan="7" style="text-align: center;"><b>AJUSTE DE DISTORSION FM MONO</b></td> </tr> <tr> <td>3</td> <td>Conectar SG-FM a terminal de antena FM refiriendo a Fig. 12. (Aplicar 60 dB a terminal de antena)</td> <td>100,10 MHz (Mod 100% con 400 Hz)</td> <td>100,10 MHz</td> <td>Conector VTVM CC entre terminal TP101 (-) y TP102 (+) a través de bobina de choque.</td> <td>T101 (Discr. IFT)</td> <td>Ajustar núcleo de T101 de manera que voltaje medido en modalidad de señal sea 0 mV en gama de 300 mV.</td> </tr> <tr> <td>4</td> <td></td> <td></td> <td></td> <td>Conectar el analizador de distorsión a terminales "OUTPUT" del aparato.</td> <td>T102 (Discr. IFT)</td> <td>Ajustar núcleo de T102 de manera que distorsión de canales derecho e izquierdo se minimice.</td> </tr> <tr> <td colspan="7" style="text-align: center;"><b>AJUSTE DE V.C.O. MPX DE FM</b></td> </tr> <tr> <td colspan="7" style="text-align: center;">USANDO UN FRECUENCIMETRO</td> </tr> <tr> <td colspan="7" style="text-align: center;">USANDO SISTEMA ALTERNATIVO</td> </tr> <tr> <td>5</td> <td colspan="3">1. Señal mono no modulada de 100,10 MHz 60 dB aplicada al aparato. 2. Interruptor de modalidad/silenciador FM a "auto". 3. Conectar frecuencímetro a TP301 a través de resistor (100kΩ) (Vea la Fig. 13) 4. Ajustar VR301 a 19 kHz ± 30 Hz.</td> <td colspan="3">1. Aplicar una señal estereofónica al aparato o recibir una emisión estereofónica. 2. Ajustar VR301 y fijar el contacto deslizante de VR301 en el medio de la gama-ON del indicador estereofónico. (Vea la Fig. 14)</td> </tr> </tbody> </table>						Nº.	GENERADOR DE SEÑALES FM		A FRECUENCIA DE PRESENTACION	PREPARACIONES	PIEZAS AJUSTADAS	PROCEDIMIENTO DE AJUSTE	CONEXION	FRECUENCIA	<b>AJUSTE DE DISTORSION FM MONO</b>							3	Conectar SG-FM a terminal de antena FM refiriendo a Fig. 12. (Aplicar 60 dB a terminal de antena)	100,10 MHz (Mod 100% con 400 Hz)	100,10 MHz	Conector VTVM CC entre terminal TP101 (-) y TP102 (+) a través de bobina de choque.	T101 (Discr. IFT)	Ajustar núcleo de T101 de manera que voltaje medido en modalidad de señal sea 0 mV en gama de 300 mV.	4				Conectar el analizador de distorsión a terminales "OUTPUT" del aparato.	T102 (Discr. IFT)	Ajustar núcleo de T102 de manera que distorsión de canales derecho e izquierdo se minimice.	<b>AJUSTE DE V.C.O. MPX DE FM</b>							USANDO UN FRECUENCIMETRO							USANDO SISTEMA ALTERNATIVO							5	1. Señal mono no modulada de 100,10 MHz 60 dB aplicada al aparato. 2. Interruptor de modalidad/silenciador FM a "auto". 3. Conectar frecuencímetro a TP301 a través de resistor (100kΩ) (Vea la Fig. 13) 4. Ajustar VR301 a 19 kHz ± 30 Hz.			1. Aplicar una señal estereofónica al aparato o recibir una emisión estereofónica. 2. Ajustar VR301 y fijar el contacto deslizante de VR301 en el medio de la gama-ON del indicador estereofónico. (Vea la Fig. 14)		
Nº.	GENERADOR DE SEÑALES FM		A FRECUENCIA DE PRESENTACION	PREPARACIONES	PIEZAS AJUSTADAS		PROCEDIMIENTO DE AJUSTE																																																								
	CONEXION	FRECUENCIA																																																													
<b>AJUSTE DE DISTORSION FM MONO</b>																																																															
3	Conectar SG-FM a terminal de antena FM refiriendo a Fig. 12. (Aplicar 60 dB a terminal de antena)	100,10 MHz (Mod 100% con 400 Hz)	100,10 MHz	Conector VTVM CC entre terminal TP101 (-) y TP102 (+) a través de bobina de choque.	T101 (Discr. IFT)	Ajustar núcleo de T101 de manera que voltaje medido en modalidad de señal sea 0 mV en gama de 300 mV.																																																									
4				Conectar el analizador de distorsión a terminales "OUTPUT" del aparato.	T102 (Discr. IFT)	Ajustar núcleo de T102 de manera que distorsión de canales derecho e izquierdo se minimice.																																																									
<b>AJUSTE DE V.C.O. MPX DE FM</b>																																																															
USANDO UN FRECUENCIMETRO																																																															
USANDO SISTEMA ALTERNATIVO																																																															
5	1. Señal mono no modulada de 100,10 MHz 60 dB aplicada al aparato. 2. Interruptor de modalidad/silenciador FM a "auto". 3. Conectar frecuencímetro a TP301 a través de resistor (100kΩ) (Vea la Fig. 13) 4. Ajustar VR301 a 19 kHz ± 30 Hz.			1. Aplicar una señal estereofónica al aparato o recibir una emisión estereofónica. 2. Ajustar VR301 y fijar el contacto deslizante de VR301 en el medio de la gama-ON del indicador estereofónico. (Vea la Fig. 14)																																																											

## LOCATION OF CONTROLS

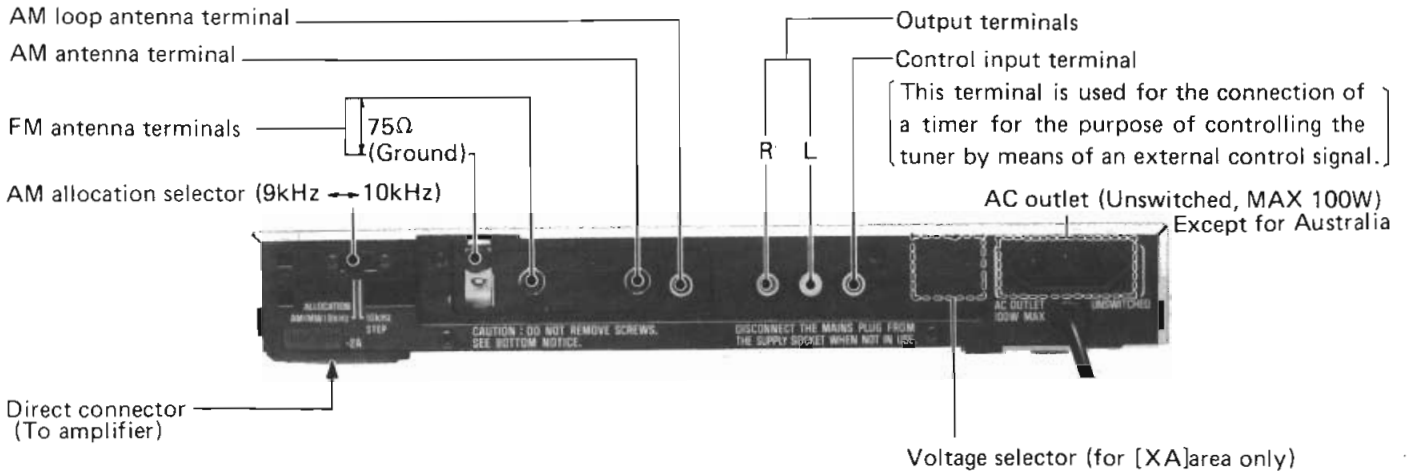
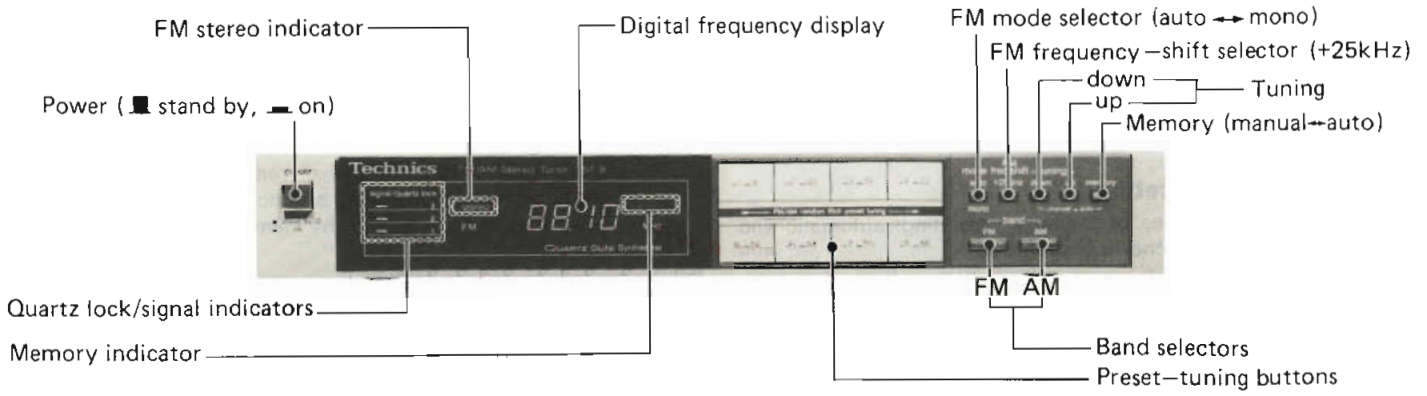

The power supply for this unit varies depending upon the areas. Also, the parts used for power supply are different. So, refer to the schematic diagram and the replacement parts list.

- \* 220V (50/60 Hz) for Continental Europe.
- \* 240V (50/60Hz) for Australia.
- \* 110V/120V/220V/240V (50/60Hz) for other area.

## CONNECTION TO AMPLIFIER

When stacking the units vertically, connect using direct connectors.

Lift the direct connector on the amplifier and move the stabilizing pin from the back panel to the upper surface.

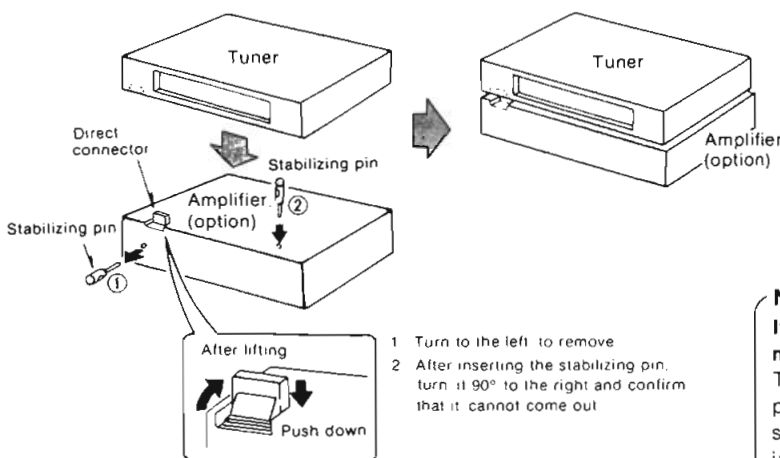

When placing the units side by side, connect them using the pin cords.

Connect the amplifier to the tuner using the pin cord.

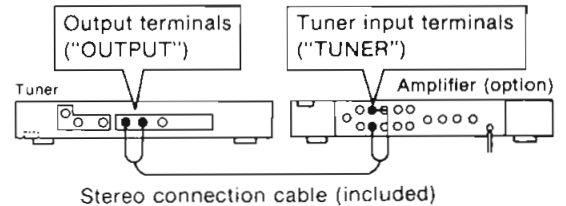

**Note:**

If the power supply is interrupted for one week or longer, the memory settings will be erased.

The memory in this unit is maintained by a gold capacitor. If the power supply is interrupted for a week or longer, set the power switch of the tuner to the "on" position for thirty minutes or more in order to recharge the gold capacitor.

## HOW TO OPERATE

This unit can be used to preset as many as 16 radio broadcast frequencies: FM/AM random presetting. After broadcast frequencies have been preset as described below, any desired station can be quickly and easily selected by simply touching one button.

### • Memory presetting

There are two types of memory presetting: automatic and manual. Select whichever is preferred.

### 1. Automatic presetting:

The FM broadcasting stations and AM broadcasting stations will be automatically preset to "channels" 1 through 8 and 9 through 16, respectively, in order upward from the broadcasting station of the lowest frequency.

Note that in mountainous or remote areas, broadcasting stations which have weak broadcasting signals cannot be automatically preset into the memory.

### 2. Manual presetting:

Stations can be freely preset to any desired "channel".

### Automatic memory presetting

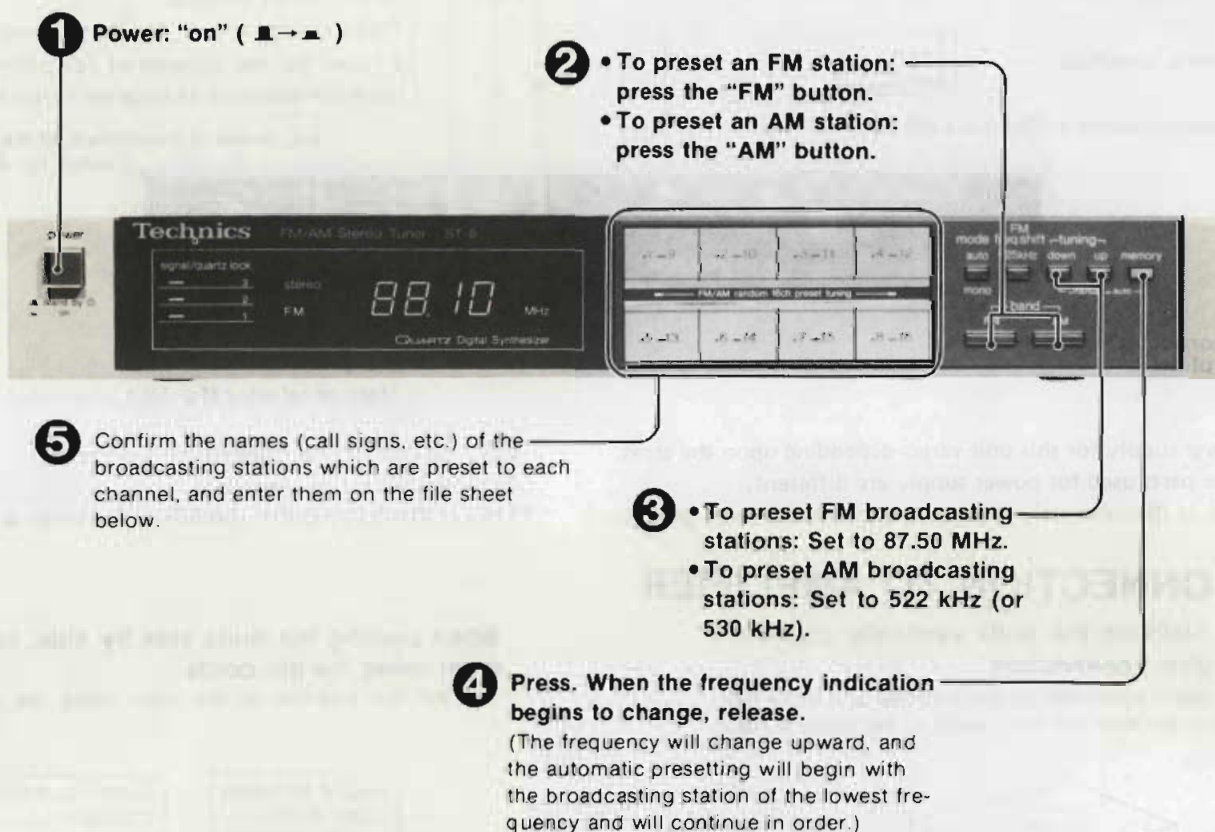

### • Notes regarding the memory presetting

#### 1. Operation of the preset-tuning buttons

Each of the preset-tuning buttons can be preset for two separate broadcasting stations; for example: channel 1 and channel 9, channel 2 and channel 10, etc.

Therefore, after presetting channel 1, press the button slightly longer in order to preset channel 9.

If the button is pressed only momentarily, the broadcasting station which is to be preset to channel 9 will be preset to channel 1, and the broadcasting station which was previously preset to channel 1 will be erased.

#### 2. Automatic memory presetting

If memory presetting is done automatically, FM broadcasting stations will automatically be entered into channels 1 through 8, and AM broadcasting stations will automatically be entered into channels 9 through 16. However, in areas where there are less than 8 FM stations, the remaining channels (through channel 8) will be left empty. The empty channels can be filled by using manual memory presetting; be sure to read carefully section 1 regarding the operation of the preset-tuning buttons.

3. If a new broadcasting station is preset into a channel, the broadcasting station which was previously entered in that channel will be automatically erased.



**Manual memory presetting**

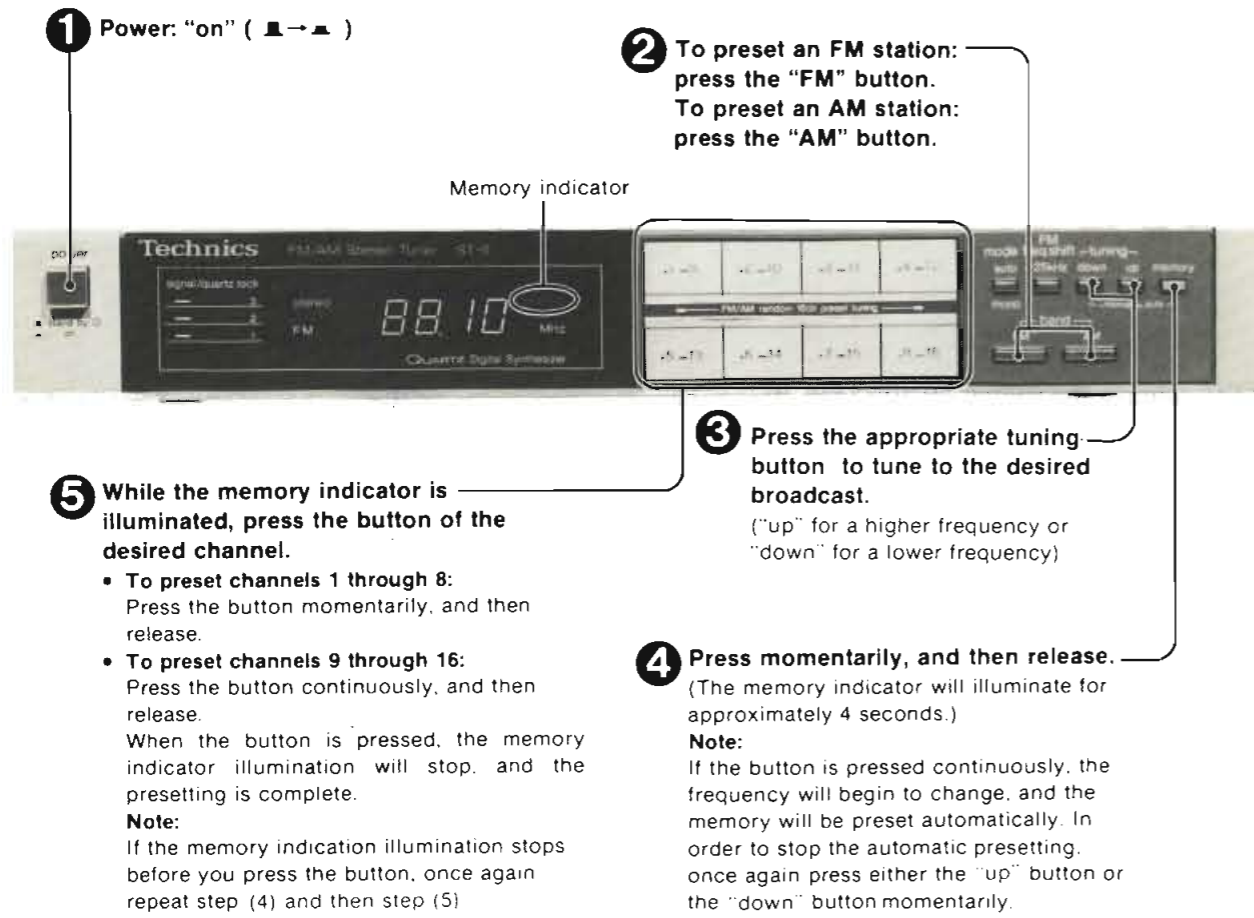

**Notes regarding manual memory presetting**

If the memory is to be preset manually, be sure to release the memory button after pressing it only momentarily. If the button is pressed continuously, the frequency will begin to

change and the memory will be preset automatically; if this happens, the broadcasting stations which were previously preset will be replaced by other broadcasting stations.

**BEFORE REPAIR**

The power switch of this unit is located on the secondary side of power transformer. So, be sure to disconnect the power cord from the socket before start of repair. Also, do the following before repair of digital circuits.

- (1) Disconnect the power cord from the socket.
- (2) Short-circuit a resistor (10Ω , 1 W) across gold capacitor (C914, 915, 2, 3V, 3.3 F) to discharge the voltage.

**DISASSEMBLY INSTRUCTIONS**

When repairing the FM front-end pack, replace it with the adjusted pack for repair.

- How to remove the cabinet [Fig. 1]
  1. Remove setscrews (Fig. 1: ①~④)
  2. Remove the cabinet in the direction of the arrow.
- How to check from the back of P. C. B. [Fig. 2,3]
  1. Remove the cabinet. (See Fig. 1.)
  2. Remove the red screws (Fig. 2: ⑤~⑨)
  3. Remove the red screws (Fig. 2: ⑩, ⑪) at top of front panel and the screws (Fig. 2: ⑫~⑭) at the bottom.
  4. Remove the setscrews (Fig. 3: ⑮, ⑯) of the rear panel.
  5. Raise the P.C.B. as in Fig. 4.

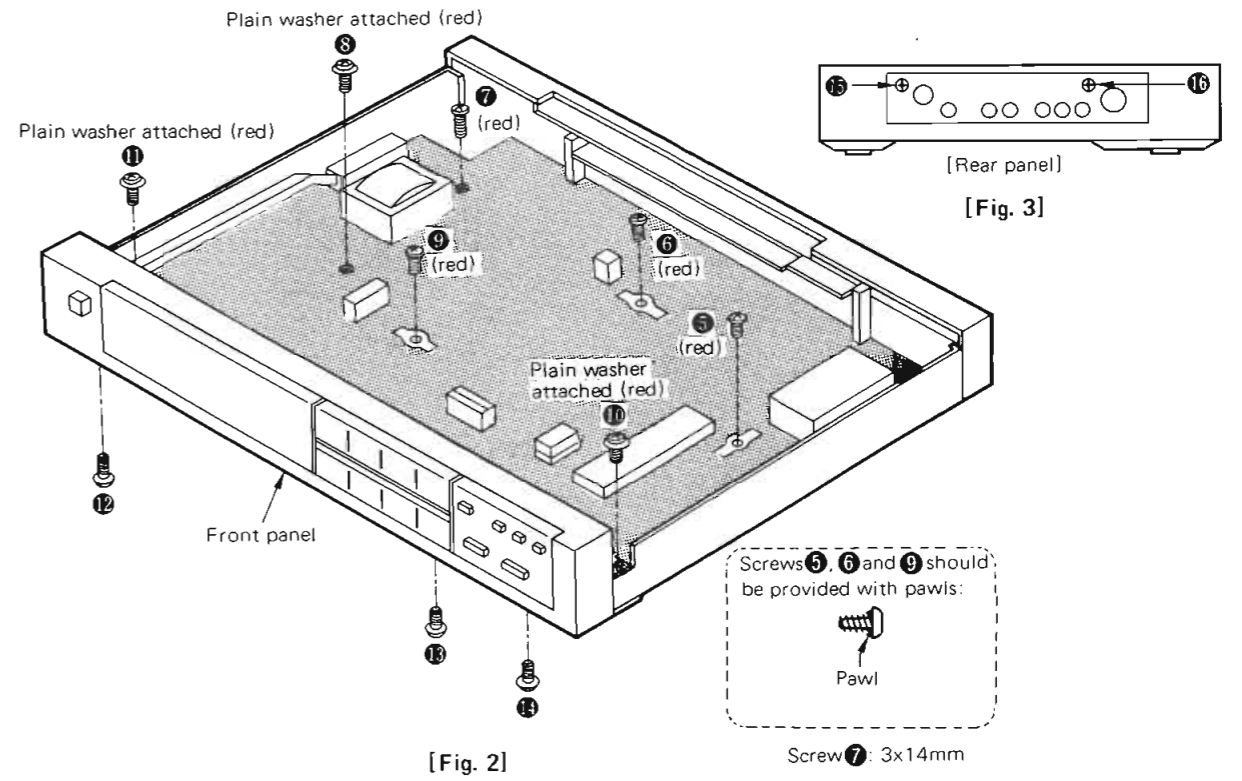
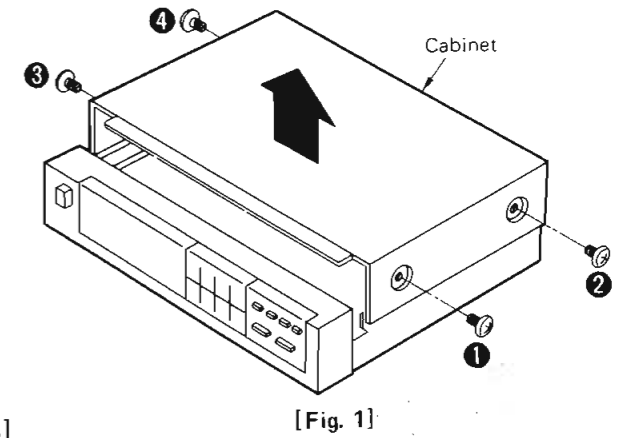

• How to set the P. C. B. [Fig. 4,5]

1. Fit the front panel in the chassis. (See Fig. 5.)
2. Fit the detents of the P.C.B. support into the holes in the P.C.B. (See Fig. 4.)
3. Tight the setscrews. (See Fig. 2,3.)

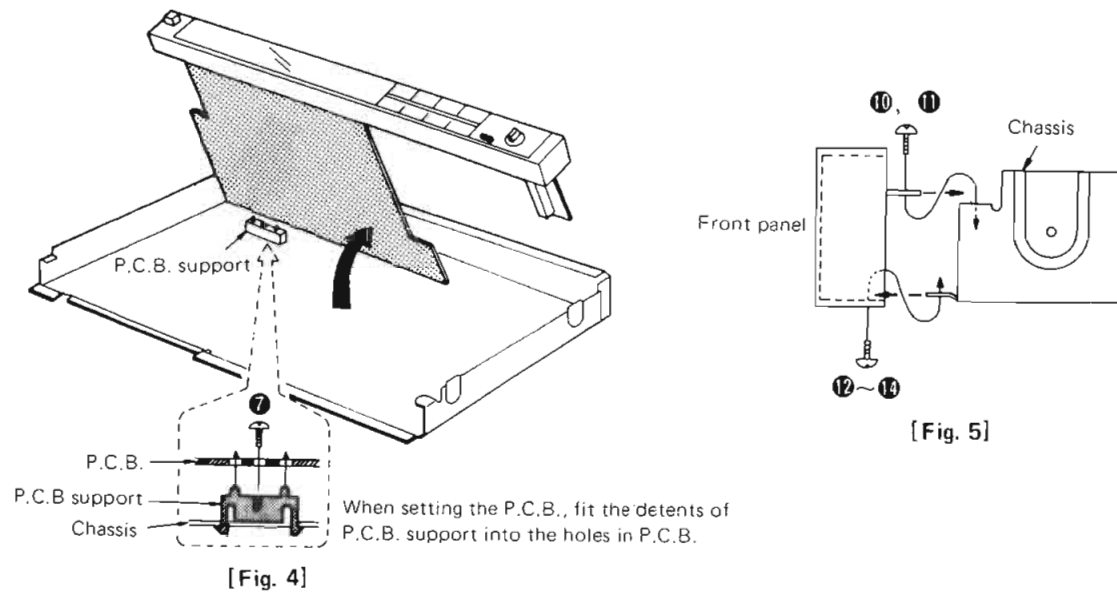

When setting the P.C.B., fit the detents of P.C.B. support into the holes in P.C.B.

• How to remove the front panel [Fig. 6,7]

1. Remove the cabinet. (See Fig.1)
2. Remove screws 10 ~ 14. (See Fig. 2.)
3. Release the 2 claws which fasten the FL display tube as in Fig. 7, and remove the display tube from the front panel. (Release the claws one after the other with care not to release too much.)
4. Disconnect the flat cable from the 3 connectors. (See Fig. 6.)
5. Remove the front panel from the chassis.
6. When setting the front panel onto the chassis, fit it in as in Fig. 5 and fasten the FL display tube with claws as in Fig. 7.

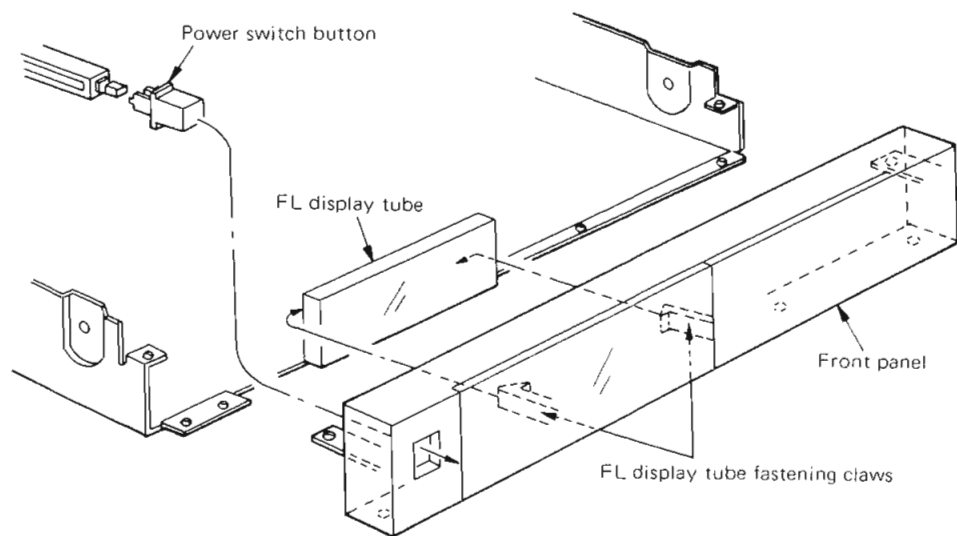
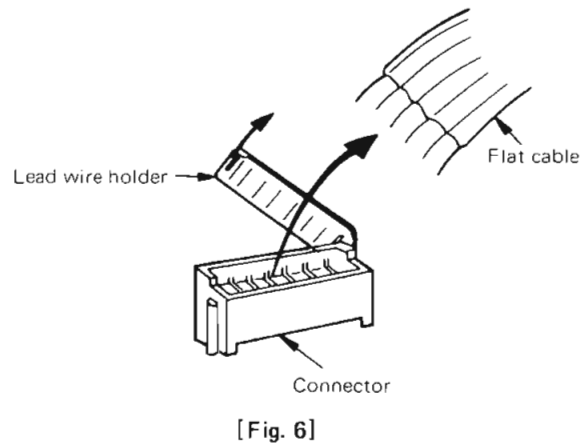

• How to remove the quartz lock/signal indicator P. C. B. and FM/AM preset tuning P.C.B [Fig. 8 ]

1. Remove the cabinet. (See Fig. 1.)
2. Remove the front panel. (See Fig. 7.)
3. Remove the setscrew (Fig. 8: 16) of the quartz lock/signal indicator.
4. Remove the setscrews (Fig. 8: 17 ~ 20) of the FM/AM preset tuning P.C.B.

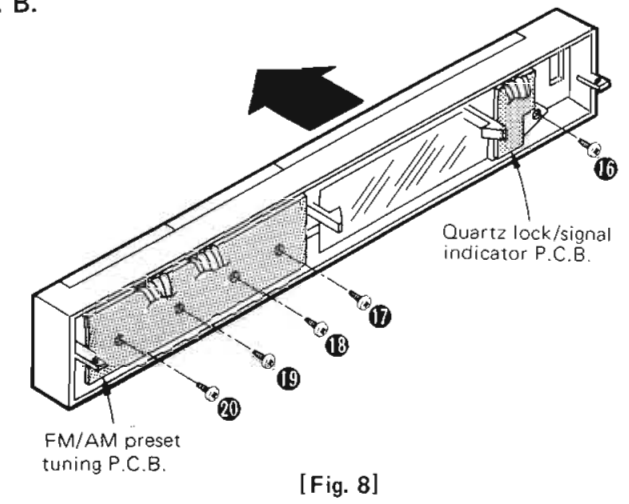

• How to remove the switch button [Fig. 9]

1. Remove the cabinet. (See Fig. 1.)
2. Remove the front panel. (See Fig. 7.)
3. Remove the FM/AM preset tuning P.C.B. (See Fig. 8.)
4. Release the claws which fasten the switch button to the front panel and remove the button forward. (Fig. 9)

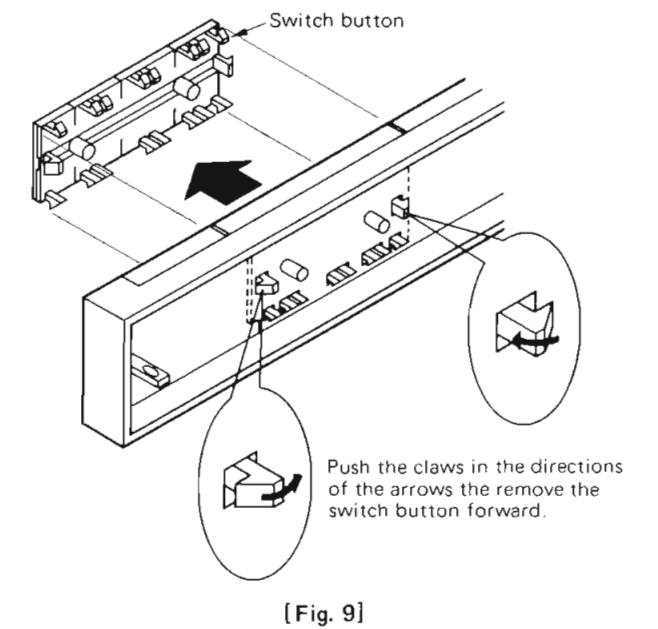

• How to remove the transparent plate [Fig. 10]

1. Remove the cabinet. (See Fig. 1.)
2. Remove the front panel. (See Fig. 7.)
3. Remove the switch button. (See Fig. 9.)
4. Remove the setscrews (Fig. 10: 21, 22) to remove the transparent plate by warping as illustrated.
5. To fit the transparent plate, first insert the side (A) into the front panel.

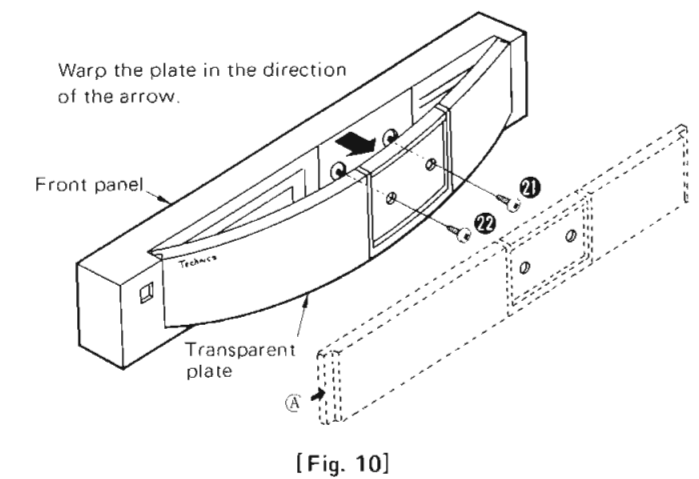

# MEASUREMENTS AND ADJUSTMENTS

Note: AM OSC coil (L203) and AM IFT (T201) have been already adjusted, and require no adjustment.

## AM ADJUSTMENT

Step No.	AM SIGNAL GENERATOR		DISPLAY FREQUENCY	PREPARATIONS	PARTS ADJUSTED	ADJUSTING PROCEDURE
	CONNECTION	FREQUENCY				
<p><b>* Setting and Equipment used</b></p> <ol style="list-style-type: none"> <li>AC electronic voltmeters (VTVM).</li> <li>AM signal generator (AM-SG).</li> <li>Set Band selector to "AM (allocation 9 kHz)" position.</li> <li>Maintain line voltage at rated voltage.</li> <li>Output of signal generator should be no higher than necessary to obtain an output reading.</li> <li>Use a non-metal screwdriver for the adjustment.</li> </ol>						
<b>AM-RF ADJUSTMENT</b>						
1	Connect AM-SG to AM antenna terminal through 200pF capacitor. Common to chassis. (Weak input)	612 kHz (30% Mod. with 400 Hz)	612 kHz	Connect AC VTVM or scope to "OUTPUT" terminals.	L202 (ANT Coil)	1. Adjust for maximum output. 2. Adjust core of L202 by screwdriver.
2	(Refer to Fig. 11)	1503 kHz (30% Mod. with 400 Hz)	1503 kHz	Connect AC VTVM or scope to "OUTPUT" terminals.	CT201 (ANT trimmer)	1. Adjust for maximum output. 2. Repeat steps (1) and (2) until the frequency correctly matches the frequency display.

## FM ADJUSTMENT

Step No.	FM SIGNAL GENERATOR		DISPLAY FREQUENCY	PREPARATIONS	PARTS ADJUSTED	ADJUSTING PROCEDURE
	CONNECTION	FREQUENCY				
<p><b>* Setting and Equipment used</b></p> <ol style="list-style-type: none"> <li>FM signal generator (FM-SG).</li> <li>Distortion analyser.</li> <li>Oscilloscope</li> <li>DC electronic voltmeters (VTVM).</li> <li>Frequency counter (19 kHz and 108 MHz measurable).</li> <li>Set band selector to "FM" position.</li> <li>Set FM mode selector to "mono" position.</li> <li>Other setting are the same as in AM adjustment.</li> </ol> <p><b>* Preparation of FM signal generator (FM-SG)</b></p> <ol style="list-style-type: none"> <li>The standard input of the set is 60 dB (1 mV), 400 Hz, 100% modulation (Because of attenuation, using coaxial cables. SG output must be 6 dB plus. That is, when input 60 dB, SG output is to be 66 dB.)</li> </ol>						
<b>FM MONO DISTORTION ADJUSTMENT</b>						
3	Connect FM-SG to FM antenna terminal referring to Fig. 12	100.10 MHz (100% Mod. with 400 Hz)	100.10 MHz	Connect DC VTVM between TP101 (-) and TP102 (+) through choke coil. (Refer to Fig. 12)	T101 (Discr. IFT)	1. Adjust T101 core so that voltage measured in signal mode is 0 mV in 300 mV range. 2. Adjust T102 core so that distortion of right and left channels are minimized.
4	(Apply 60 dB to antenna terminal.)			Connect distortion analyser to "OUTPUT" terminals.		
<b>FM MPX V.C.O. ADJUSTMENT</b>						
USING A FREQUENCY COUNTER			USING ALTERNATE SYSTEM			
5	1. 100.10 MHz, 60 dB Non-modulated mono signal applied to set. 2. FM mode switch to "auto" position. 3. Connect frequency counter to TP301 through resistor (100k Ω) referring to Fig. 13 4. Adjust VR301 to 19 kHz ± 30 Hz.			1. Apply stereo signal from generator or stereo station to tuner. 2. Adjust VR301 until stereo indicator lights up. Cement arm of VR301 as shown in Fig. 14.		

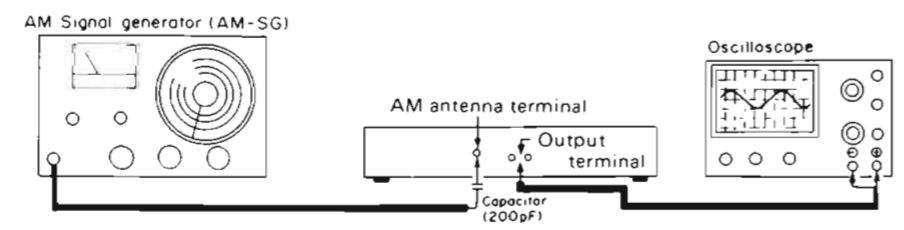

Fig. 11(Adjustment of AM)

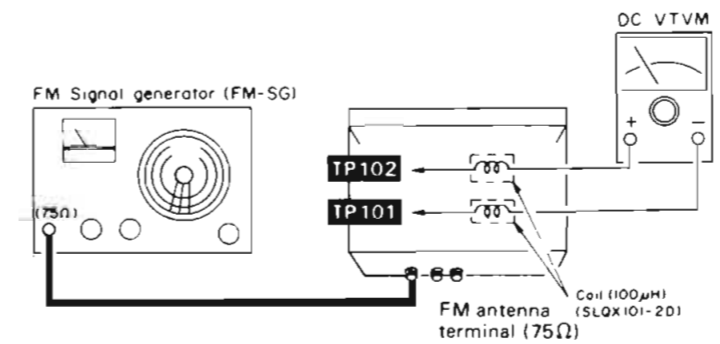

Fig. 12 (Adjustment of FM offset)

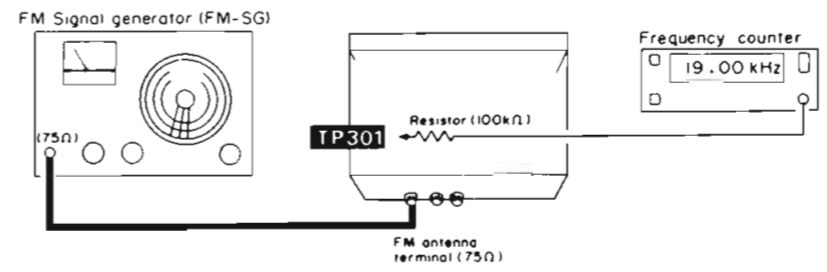
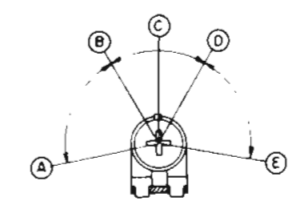

Fig. 13 (Adjustment of FM MPX VCO)



VR301  
 A-B, D-E : Stereo OFF position.  
 B-D : Stereo ON position. (indicator lighting)  
 C : Adjust point of pilot circuit

Fig. 14 (Adjustment of FM MPX VCO)

### About test point

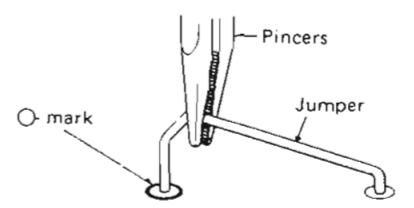

It can be removed by pulling the O - marked side by use of pincers. Insert it into the original hole when not needed.

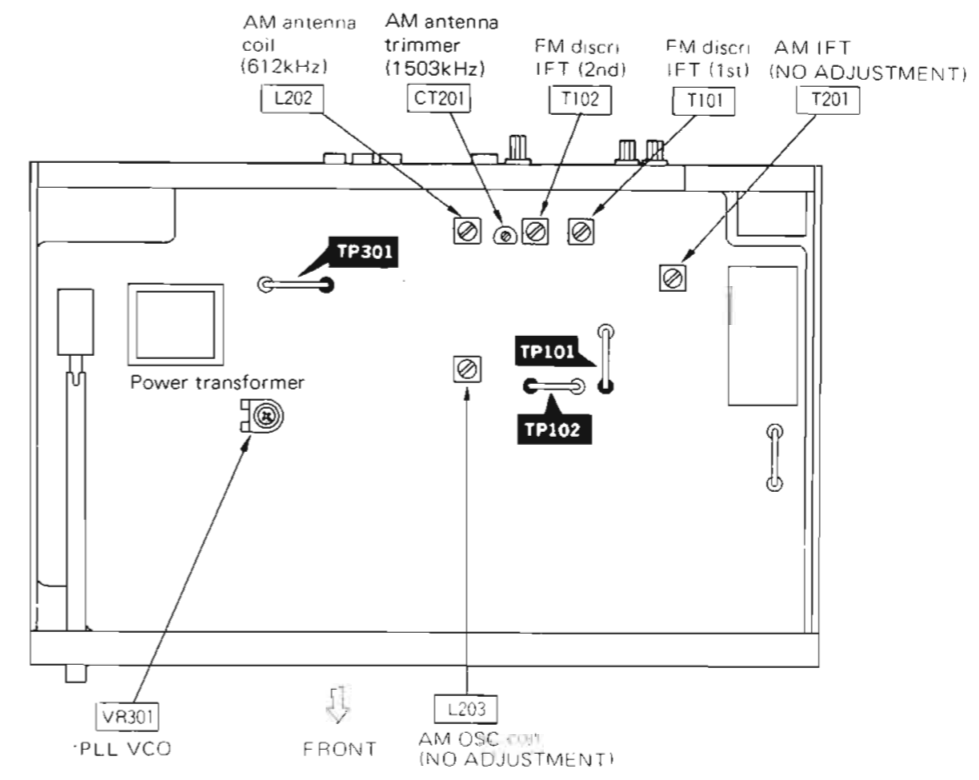

# CIRCUIT BOARD AND WIRING CONNECTION DIAGRAM

Ground (Earth) lines

- ① Tuner signal(R)
- ② Tuner signal(L)
- ③ Ground
- ④ Tuner → Amp input change over
- ⑤
- ⑥

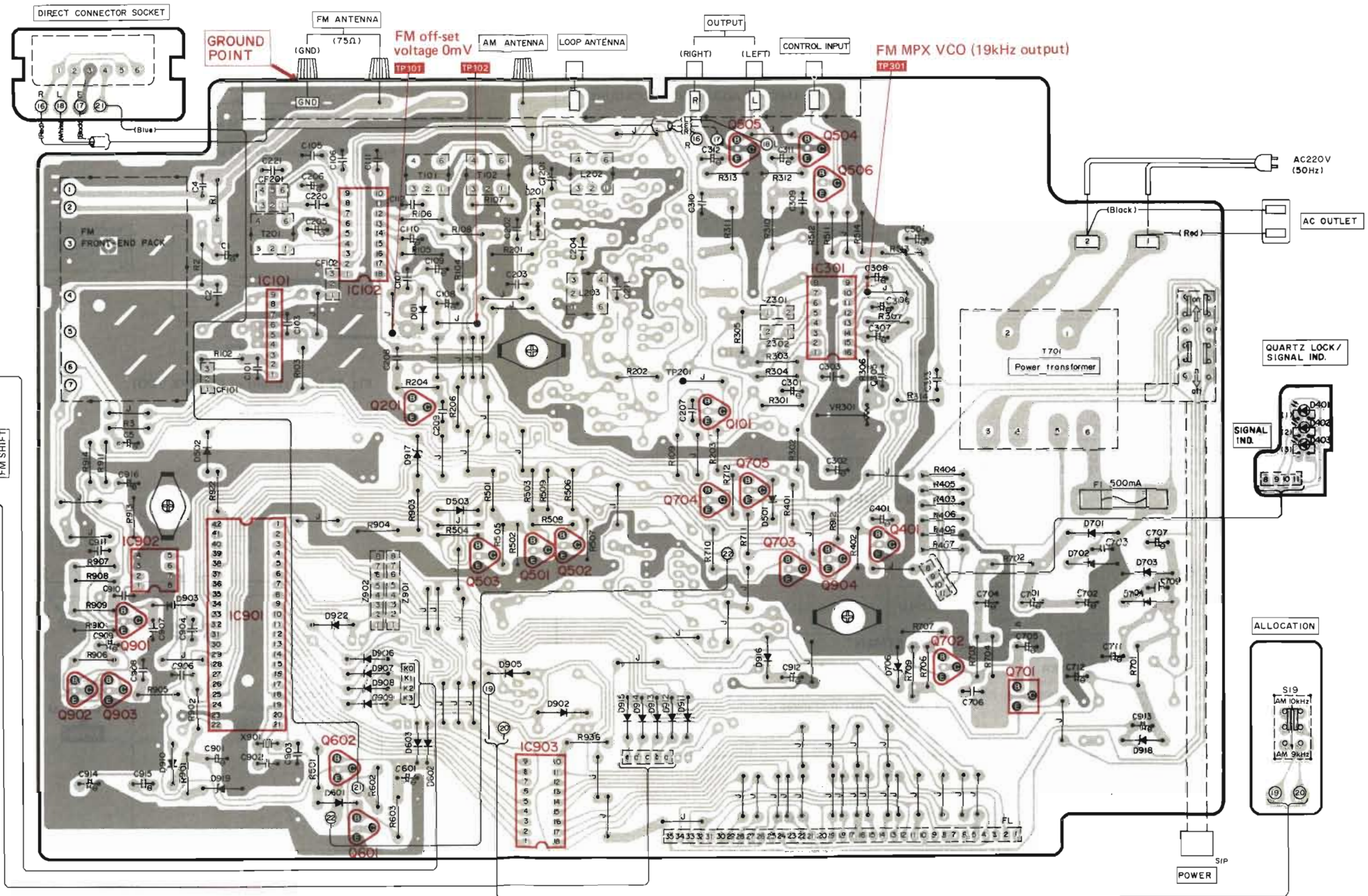

# RESISTORS AND CAPACITORS

**Notes:** 1. Part numbers are indicated on most mechanical parts. Please use this part number for parts order.  
2. Important safety notice. Components identified by  $\Delta$  mark have special characteristics important for safety. When replacing any of these components use only manufacturer's specified parts.

3. The "S" mark is service standard parts and may differ from production parts.  
4. The unit of resistance is OHM ( $\Omega$ ).  
K = 1000 $\Omega$  M = 1000k $\Omega$   
5. The unit of capacitance is MICROFARAD ( $\mu$ F).  
P = 10<sup>-6</sup>  $\mu$ F

## Numbering System of Resistor

Example	ERD	25	F	J	101
Type	Wattage	Shape	Tolerance		Value

Resistor Type	Wattage	Tolerance
ERD : Carbon	25 : 1/4W	J : $\pm$ 5%
ERQ : Fuse Type	1 : 1W	
	S1 : 1/2W	

## Numbering System of Capacitor

Example	ECKD	1H	102	Z	F
Type	Voltage	Value	Tolerance	Peculiarity	
ECEA	50	M	R47	R	
Type	Voltage	Peculiarity use	Value	Special use	

Capacitor Type	Voltage		Tolerance
	ECEA Type	Other	
ECEA : Electrolytic	0J : 6.3V	1H : 50V DC	C : $\pm$ 0.25 $\mu$ F
ECCD : Ceramic	1C : 16V	2H : 500V DC	J : $\pm$ 5%
ECKD : Ceramic	1E : 25V	2R3 : 2.3V DC	K : $\pm$ 10%
ECQM : Polyester	1H : 50V	1 : 125VDC	Z : +80%, -20%
ECQP : Polypropylene	50 : 50V		
EECW : Liquid electrolyte double layer capacitor	25 : 25V		

## RESISTORS

Ref. No.	Part No.	Value	Ref. No.	Part No.	Value	Ref. No.	Part No.	Value	Ref. No.	Part No.	Value
R1	ERD25TJ104	100K	R305	ERD25TJ274	270K	R507	ERD25TJ473	47K	R901	ERD25FJ681	680
R2	ERD25TJ273	27K	R306	ERD25TJ153	15K	R508, 509	ERD25TJ563	56K	R902	ERD25FJ103	10K
R3	ERD25FJ151	150	R310, 311	ERD25FJ332	3.3K	R511	ERD25FJ102	1K	R903	ERD25FJ472	4.7K
R102	ERD25FJ331	330	R312, 313	ERD25TJ333	33K	R512	ERD25TJ104	100K	R904	ERD25FJ562	5.6K
R103	ERD25FJ681	680	R314	ERD25TJ154	150K	R513	ERD25TJ103	10K	R905	ERD25FJ102	1K
R104	ERD25FJ471	470	R401	ERD25FJ182	1.8K	R514	ERD25TJ104	100K	R906	ERD25FJ561	560
R105	ERD25FJ102	1K	R402	ERD25FJ562	5.6K	R601	ERD25FJ103	10K	R907	ERD25FJ102	1K
R106	ERD25FJ472	4.7K	R403	ERD25FJ821	820	R602	ERD25TJ223	22K	R908	ERD25FJ682	6.8K
R107	ERD25FJ272	2.7K	R404	ERD25FJ331	330	R603	ERD25TJ104	100K	R909	ERD25TJ123	12K
R108	ERD25FJ471	470	R405	ERD25FJ151	150	R701	ERD25FJ681	680	R910	ERD25FJ682	6.8K
R109	ERD25TJ104	100K	R406	ERD25FJ121	120	R702	ERQ1CJ680	68	R911	ERD25FJ822	8.2K
R201	ERD25TJ104	100K	R407	ERD25FJ100	10	R703	ERD25FJ122	1.2K	R912	ERD25TJ104	100K
R202	ERD25FJ561	560	R408	ERD25FJ122	1.2K	R704	ERD25FJ2R2	2.2	R913	ERD25TJ684	680K
R203	ERD25FJ102	1K	R501	ERD25FJ153	15K	R706	ERD25FJ472	4.7K	R914	ERD25FJ101	100
R204	ERD25TJ684	680K	R502	ERD25TJ104	100K	R707	ERD25FJ392	3.9K	R920	ERD25FJ102	1K
R206	ERD25FJ102	1K	R503	ERD25TJ563	56K	R709	ERD25FJ391	390	R922	ERD25FJ103	10K
R301	ERD25TJ393	39K	R504	ERD25TJ473	47K	R710	ERD25TJ473	47K	R936	ERD25FJ390	39
R302	ERD25FJ680	68	R505	ERD25TJ393	39K	R711	ERD25FJ103	10K			
R303, 304	ERD25TJ223	22K	R506	ERD25TJ104	100K	R712	ERD25TJ473	47K			

## CAPACITORS

Ref. No.	Part No.	Value	Ref. No.	Part No.	Value	Ref. No.	Part No.	Value	Ref. No.	Part No.	Value
C1	ECEA50Z3R3	3.3	C204	ECQP1471JZ	470P	C309, 310	ECQM1H153KV	0.015	C712	ECEA1VS101	100
C2	ECKD1H103ZF	0.01	C205	ECEA1S101	100	C311, 312	ECEA50ZR47	0.47	C901	ECEA0JS102	1000
C4	ECCD1H101K	100P	C206	ECEA25Z4R7	4.7	C313	ECKD1H103ZF	0.01	C902	ECCD1H070CC	7P
C5	ECEA1ES101	100	C207	ECQM1H183KV	0.018	C401	ECEA50Z3R3	3.3	C903	ECCD1H180KC	18P
C101, 103	ECKD1H103ZF	0.01	C208	ECCD1H390K	39P	C501	ECEA50Z1	1	C904	ECKD1H103ZF	0.01
C105, 106	ECKD1H223ZF	0.022	C209	ECKD1H103ZF	0.01	C601	ECEA50Z4R7	0.47	C906, 907	ECKD1H103ZF	0.01
C107	ECKD1H223ZF	0.022	C211	ECKD1H223ZF	0.022	C701, 702	ECEA1ES471	470	C908	ECKD1H103ZF	0.01
C108	ECEA1HS010	10	C220	ECCD1H080CC	8P	C703	ECKD2H681KB	680P	C909	ECEA50M4R7R	4.7
C109, 110	ECEA1HS100	10	C301	ECEA1HS100	10	C704	ECEA1HU221	220	C910	ECKD1H103ZF	0.01
C111	ECKD1H223ZF	0.022	C302	ECEA1CS221	220	C705	ECEA1CS471	470	C911	ECKD1H223ZF	0.022
C112	ECCD1H101K	100P	C303	ECQM1H473KV	0.047	C706	ECKD1H103ZF	0.01	C912	ECEA1AS101	100
C122	ECCD1H470K	47P	C305	ECQP1471JZ	470P	C707	ECEA1HS470	47	C913	ECEA50Z3R3	3.3
C202	ECQM1H473KV	0.047	C306	ECEA50Z1	1	C709	ECKD2H681KB	680P	C914, 915	ECEA50Z3R3	3.3
C203	ECCD1H120KC	12P	C307	ECEA50Z3R3	3.3	C711	ECEA1HS470	47	C916	ECEAES101	100

# FUNCTION OF TERMINAL (PLL CONTROLLER IC901)

Pin No.	Mark	Description of terminal
1	Sa	Segment signal output terminal for display. (Refer to Fig. 15)
2	Sb	
3	Sc	
4	Sd	
5	Se	
6	Sf	
7	Sg	
8	K0	Input terminal for key return signal from external key matrix. The output of segment terminals (Sa~Sg) is used as the key return signal source.
9	K1	
10	K2	
11	K3	
12	D6	Digit signal output terminal for display. (Refer to Fig. 15)
13	D5	
14	D4	
15	D3	
16	D2	
17	D1	
18	MT	This is the output terminal to eliminate shock noise due to unlocking at PLL. When the CE terminal is at low level, the output from this terminal is at high level.
19	X2	Connecting terminal for crystal oscillator. The crystal connected is at 4.5 MHz.
20	X1	
21	VDD	Power supply terminal of the device.
22	E01	Not used in this unit.
23	GND	Ground terminal.
24	E02	When the divided oscillation frequency is higher than the standard frequency, H-level output is delivered from these terminals. When it is lower, L-level (0V) output is delivered. When they coincide, it results in floating.
25	CE	This is the selected signal input terminal of the device. When operating the device, make the level high, and when it is not used, make the level low. When this terminal is at low level, all the segment (a~g) and digits (D1~D6) terminals are off, but the memory is held.
26	SD	This input terminal detects the reception of a broadcasting station. The voltage is 4.2V during reception, and otherwise 0V.
27	FM	Input terminal for FM OSC output frequency-divided to 1/16 or 1/17 by pre-scaler.

Pin No.	Mark	Description of terminal
28	PSC	This is the terminal to deliver the frequency dividing ratio changeover output signal to the pre-scaler. The terminal continues to produce pulses at the rise of the signal applied to FM terminal (27) until the content of the inside swallow counter is 0. When the swallow counter comes to 0, the terminal level becomes low, then the frequency dividing ratio of pre-scaler is 1/16.
29	INT	This is the interrupt demand signal input terminal. The signal from the control input terminal is put into this terminal, demanding for interruption, then the flow of program will be unconditionally shifted to the address No. 1.
30	AM	Input terminal for AM OSC output.
31	Dp	2-bit input/output. Dp (31) is decimal point indication output terminal for digital indication. Lamp (32) is not used in this unit.
32	Lamp	
33	IF	4-bit output port. FM (35) is FM/AM output terminal; 5V in FM and 0V in AM. IF (33), LW (34) and AM (36) not used in this unit.
34	LW	
35	FM	
36	AM	
37	OFF	This is 4-bit input/output port. MONO terminal (38) is the auto/mono changeover output terminal, which is 5V in auto, and 0V in mono. OFF(37), SDC(39) and D(40) not used in this unit.
38	MONO	
39	SDC	
40	D	
41	COMP	One-bit input/output port. (Not used in this unit.)
42	VDP	One-bit output port. (Not used in this unit.)

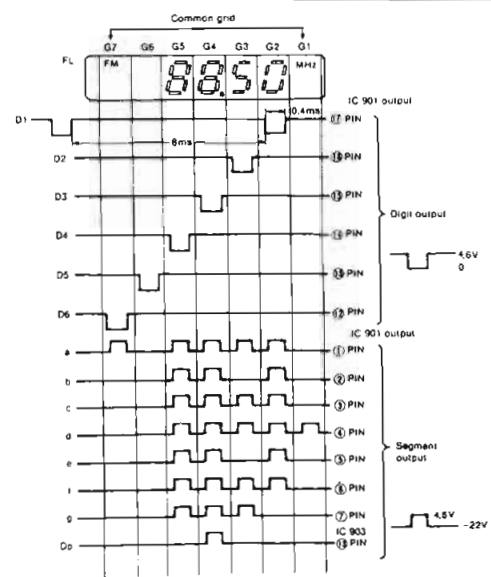
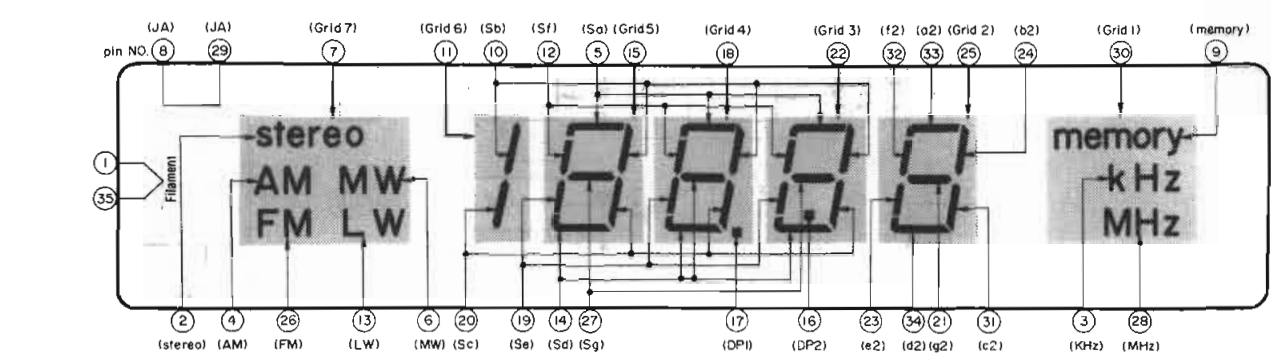
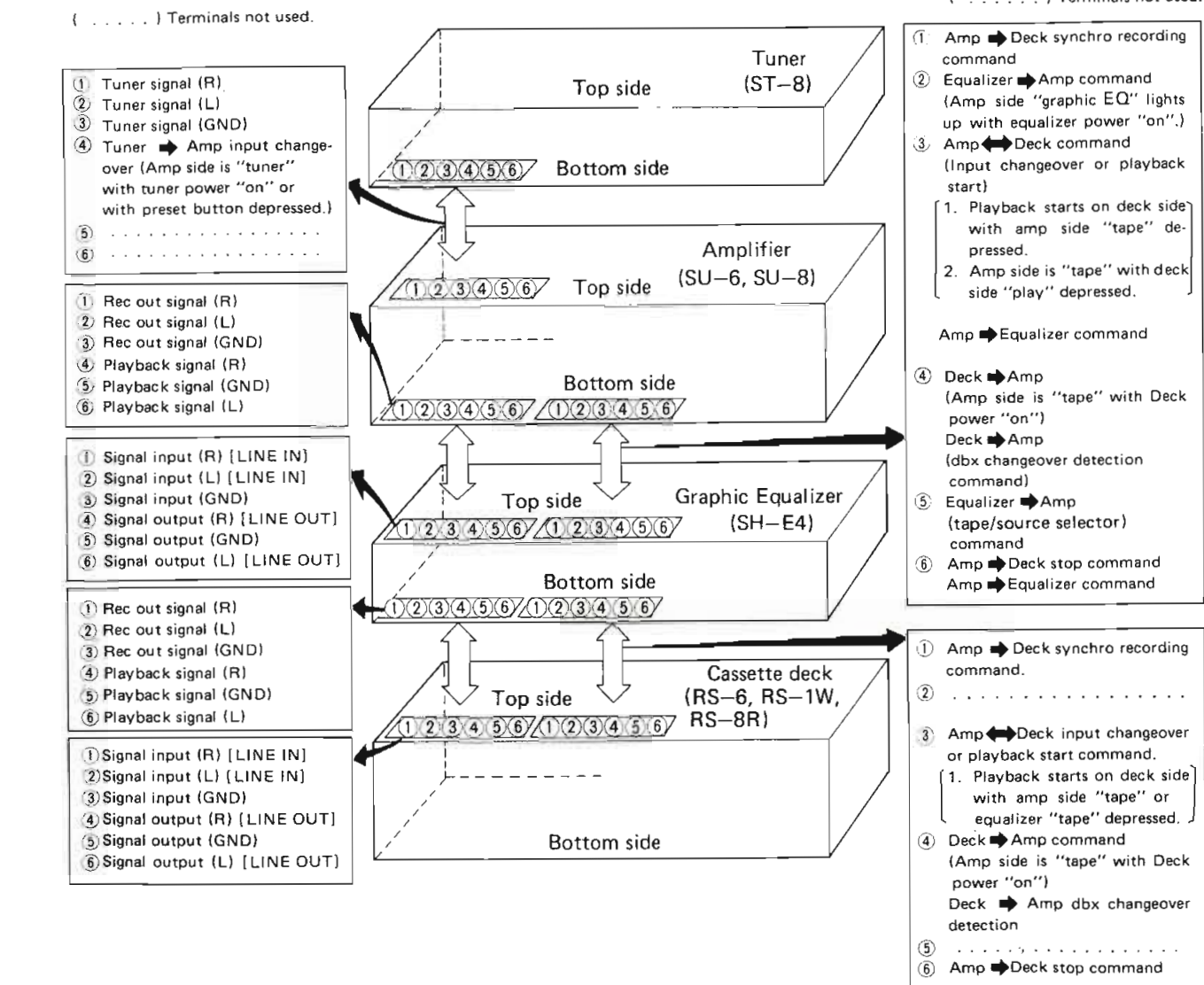

Fig. 15

## Fluorescent Display Tube (FL)



## TERMINAL FUNCTION OF DIRECT CONNECTOR



Terminal ⑥ is not used in RS-1W.

■ BLOCK DIAGRAM

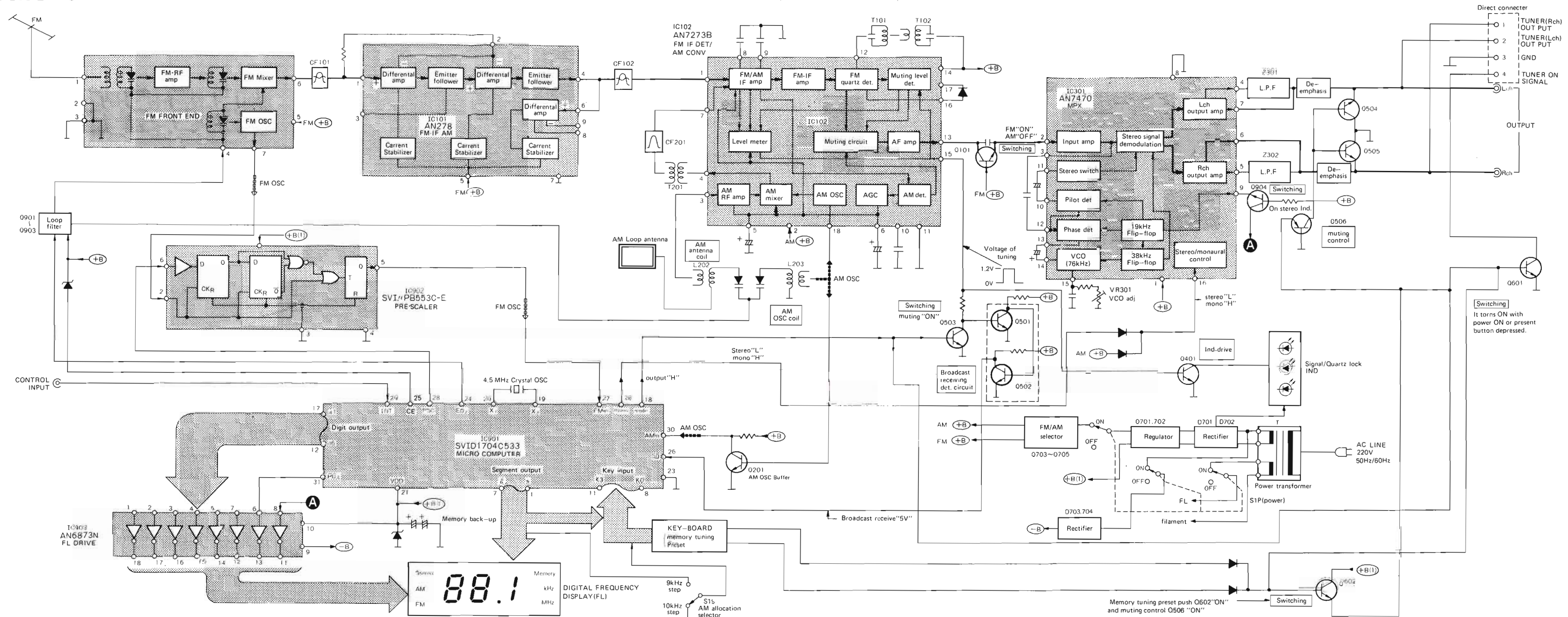

● Terminal guide of transistors, diodes and IC's

<table border="1"> <tr><td>SVID1704C533</td><td>42Pin</td></tr> <tr><td>AN7273B</td><td>18Pin</td></tr> <tr><td>AN7470</td><td>16Pin</td></tr> <tr><td>SVIUPB553C-E</td><td>8Pin</td></tr> </table>	SVID1704C533	42Pin	AN7273B	18Pin	AN7470	16Pin	SVIUPB553C-E	8Pin	<table border="1"> <tr><td>2SC1685, 2SA722</td><td></td></tr> <tr><td>2SD762</td><td></td></tr> <tr><td>MA150</td><td></td></tr> <tr><td>MA27W-A</td><td></td></tr> <tr><td>SVDKV1236Z</td><td></td></tr> <tr><td>SVDSR1K2</td><td></td></tr> <tr><td>SVDMZ □□□□</td><td></td></tr> <tr><td>LN417YP</td><td></td></tr> <tr><td>AN278</td><td></td></tr> </table>	2SC1685, 2SA722		2SD762		MA150		MA27W-A		SVDKV1236Z		SVDSR1K2		SVDMZ □□□□		LN417YP		AN278	
SVID1704C533	42Pin																										
AN7273B	18Pin																										
AN7470	16Pin																										
SVIUPB553C-E	8Pin																										
2SC1685, 2SA722																											
2SD762																											
MA150																											
MA27W-A																											
SVDKV1236Z																											
SVDSR1K2																											
SVDMZ □□□□																											
LN417YP																											
AN278																											

Note 2:

● Use of ceramic filters in pairs  
 The ceramic filters (CF101 and CF102) for FM-IF circuit are available in two ranks. For this machine, be sure to use the ceramics of the same rank in a pair. At repairing and replacement, pay close attention to the diode (D902) for use as different diodes must be used depending on each rank of the ceramic filters.

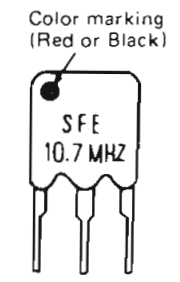

RANK (Color)	D902	CENTER FREQUENCY
Black	○	10.65 MHz
Red	X	10.70 MHz

Note ○ Mark Diode is used.  
 X Mark Diode is not used.

### SCHEMATIC DIAGRAM

(This schematic diagram may be modified at any time with the development of new technology.)

\* The part No. of transistors, IC and diodes mentioned in the schematic diagram stand for production part No. Regarding the part No. with ⊕ mark, the production part No. are different from the replacement part No. Therefore, when placing an order for replacement part, please use the part No. in the replacement part list.

\* This is the basic circuit diagram (For continental Europe) of this unit. Note that part of the circuit is subject to change depending on the areas.

- Note 1:**
- 1. S1P : Power switch in "on" position.
  - 2. S1~8 : Preset tuning switch
    - \* With it lightly pushed (less than 0.4 sec.) and released the 1~8 CH (front stations) are received.
    - \* With it continuously pushed (0.4 sec. or more) and released, the 9~16 CH (back stations) are received.
  - 3. S9 : FM mode selector switch (auto → mono)
  - 4. S10 : FM frequency — shift switch.
  - 5. S11 : Tuning (down) switch (manual → auto).  
[down: tuning to lower frequency]
  - 6. S12 : Tuning (up) switch (manual → auto).  
[up: tuning to upper frequency].
  - 7. S13 : Memory set switch (manual → auto)
  - 8. S14 : Band selector (FM) switch.
  - 9. S15 : Band selector (AM) switch.
  - 10. S17[XA] : Voltage selector switch in "220V" position.  
110V → 120V → 220V → 240V
  - 11. S19 : AM allocation selector switch in "10 kHz step" position.

12. Indicated voltage values are the standard values for the unit measured by the DC electronic circuit tester (high-impedance) with the chassis taken as standard. Therefore, there may exist some errors in the voltage values, depending on the internal impedance of the DC circuit tester.

\* Figures in stand for DC voltage in FM signal (no signal) reception mode.  
\* Figures in stand for DC voltage in FM stereo signal reception mode.  
\* Figures in stand for DC voltage in AM signal reception mode.

- 13. Positive voltage lines
- FM signal
- AM signal
- AF signal lines
- FM IF
- AM IF

14. Important safety notice. Components identified by Δ mark have special characteristics important for safety. When replacing any of these components, use only manufacturer's specified parts.

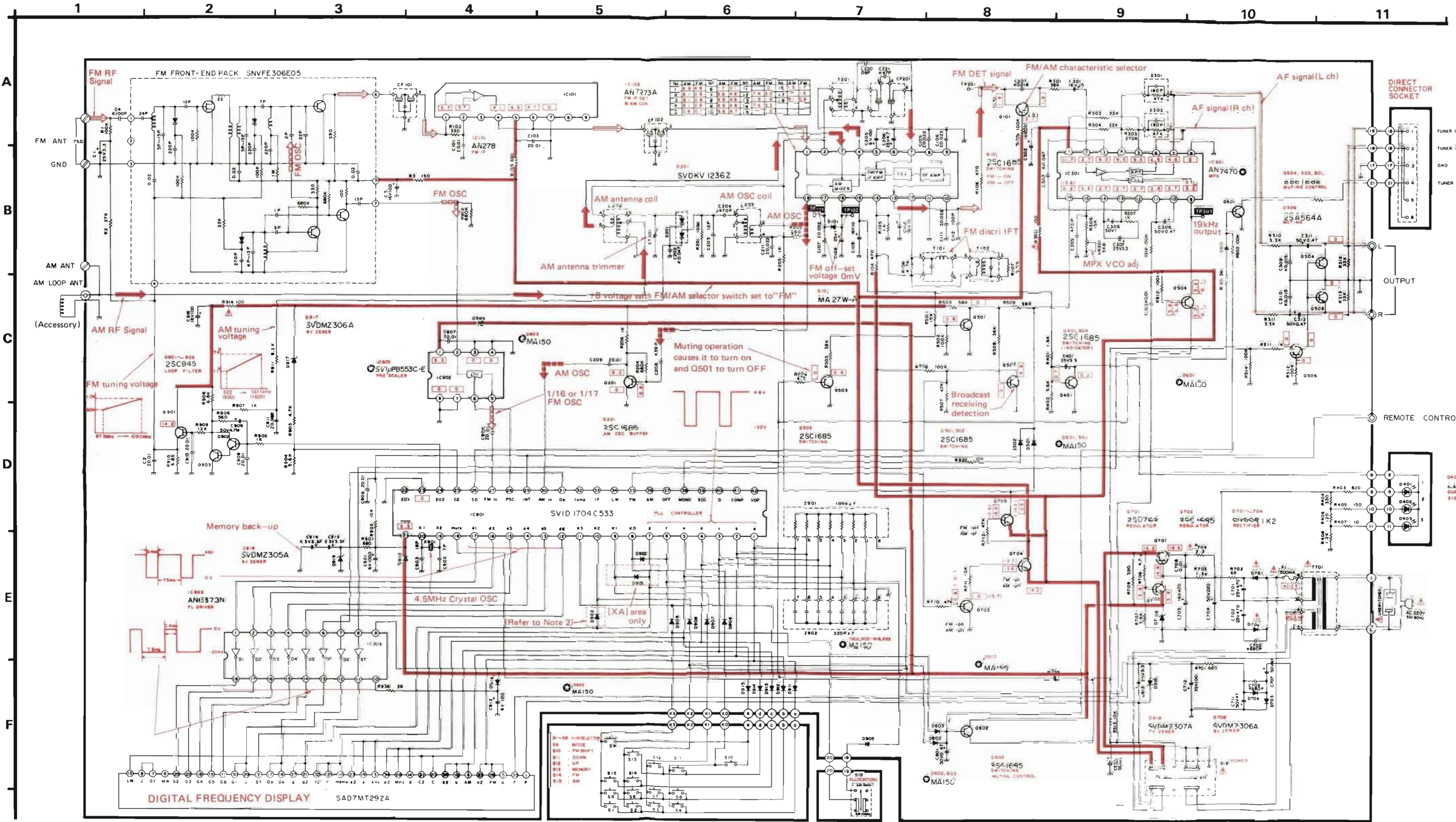
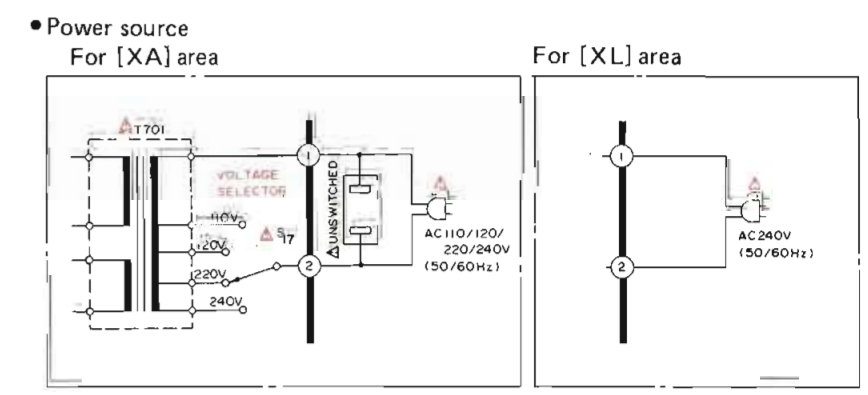

### REPLACEMENT PARTS LIST

- Notes:**
- Part numbers are indicated on most mechanical parts. Please use this part number for parts order.
  - Important safety notice: Components identified by  $\Delta$  mark have special characteristics important for safety. When replacing any of these components, use only manufacturer's specified parts.
  - $\text{\textcircled{K}}$  - marked parts are used for black only, while  $\text{\textcircled{O}}$  - marked parts are for silver type only.
  - Part other than  $\text{\textcircled{K}}$  - and  $\text{\textcircled{O}}$  - marked are use for both black and silver type.

- Bracketed indications in Ref. No. columns specify the area. Parts without these indications can be used for all areas.
- The " $\text{\textcircled{S}}$ " mark is service standard parts and may differ from production parts.
- The parenthesized numbers in the column of description stand for the quantity per set.

Black type model No. ST-8(K)

**Areas**

- \* [EX] is available in Switzerland and Scandinavia.
- \* [EH] is available in Holland.
- \* [XA] is available in Southeast Asia, Oceania, Africa, Middle Near East and Central South America.

- \* [XL] is available in Australia.
- \* [XM] is available in Mexico.

Ref. No.	Part No.	Part Name & Description
<b>INTEGRATED CIRCUITS</b>		
IC101	AN278	FM IF AMP
IC102	AN7273A	FM/AM DET
IC301	SVIUPC1161C3	FM MPX
IC901	SVID1704C533	PLL Control
IC902	SVIUPB553AC	Pre Scaler
IC903	AN6873N	FL Drive
<b>TRANSISTORS</b>		
Q101, 201, 602	2SC1685-QNC	Switching, OSC, Mute
Q501~503	2SC1685-QNC	Switching
Q601, 702, 703	2SC1685-QNC	Regulator
Q904	2SC1685-QNC	Switching
Q401, 504, 505	2SC1685-QNC	LED Switching
Q506	2SA722-S	Switching
Q701	2SD762-O	Regulator
Q704, 705	2SA722-S	FM/AM Selector
Q901, 902, 903	2SC945-Q	Loop Filter
<b>DIODES</b>		
D101	MA27W-A	Switching
D201	SVDKV1236Z	Variable Capacitance
D401~403	LN417YP	LED Ind. Signal
D501~503, 601~603, 902, 903, 905~916, 922, 925	MA162A	Switching
D701~704	SVDSR1K2	Rectifier
D706, 917	SVDMZ306A	6V Zener
D918	SVDMZ307A	7V Zener
D919	SVDMZ305A	5V Zener
<b>COILS</b>		
L202	SLA2C5-P	AM Antenna Coil
L203	SL02C29R-P	AM OSC
<b>TRANSFORMERS</b>		
T101	SLI4C535-Z	FM IFT
T102	SLI4C537-Z	FM IFT
T201	SLI2C143-M	AM IFT
T701 [EX,EH]	SLT5K141	Power Source
T701 [XL]	SLT5J191	Power Source
T701 [XA]	SLT5K145	Power Source
<b>CERAMIC FILTER</b>		
CF101, 102	SVFE107MM-A	FM, 10.7MHz (Red)
	SVFE107MM-D	FM, 10.65MHz (Black)
CF201	SVFSFZ450F7L	AM, 450KHz
<b>CRYSTAL</b>		
X901	SVQ49U452-T	4.5MHz Counter OSC
<b>VARIABLE RESISTOR</b>		
VR301	EVN75AA00B53	FM MPX VCO Adj, 5k $\Omega$ (B)

Ref. No.	Part No.	Part Name & Description
<b>VARIABLE CAPACITOR</b>		
CT201	SVCT203T110F	AM Ant. Trimmer
<b>COMPONENT COMBINATIONS</b>		
Z301, 302	EXRP181K473C	180PF $\times$ 1, 47k $\Omega$ $\times$ 1
Z901	EXBP87104K	100k $\Omega$ $\times$ 7
Z902	EXFP7331MW	330pF $\times$ 7
<b>SWITCHES</b>		
S1P	SSH1069	Power Source
S1~15	SSG13	Preset Bottom
S17(XA)only	SSR187	Voltage Selector
S19	SSS43	Allocation
<b>FUSE</b>		
F1	XBA2C05TR0	T500mA, 250V
<b>FLUORESCENT DISPLAY TUBE</b>		
FL	SAD7MT29ZA	Frequency Display
<b>FM PACK</b>		
	SNVFE306E05	FM RF Pack
<b>CABINET and CHASSIS PARTS</b>		
1	SGW49305B	Front Panel (Silver) (1)
1	SGW49308A	Front Panel (Black) (1)
2	SBC603-1	Button, Selector (1)
3	SKD4790	Transparent Plate (Silver) (1)
3	SKD4792	Transparent Plate (Black) (1)
4	SGU375-1SA	Ornament Plate (Silver) (1)
4	SGU375-1BA	Ornament Plate (Black) (1)
5	SBC601	Button, Selector (Silver) (1)
5	SBC601-3	Button, Selector (Black) (1)
6	SDU213	Filter, FL (1)
7	SBC489	Button, Power (1)
8	SUB111-2	Connection Rod, Power (1)
9	SHE129-1	Spacer, P. C. B (1)
10(EX)	SKUT8-SE	Bottom Board Ass'y(W/Foot) (1)
10(EH)	SKUT8-SH	Bottom Board Ass'y(W/Foot) (1)
10(XA)	SKUT8-SX	Bottom Board Ass'y(W/Foot) (1)
10(XL)	SKUT8-SL	Bottom Board Ass'y(W/Foot) (1)
10(XM)	SKUT8-SY	Bottom Board Ass'y(W/Foot) (1)
10-1	SKL245-2	Foot (4)

Ref. No.	Part No.	Part Name & Description
<b>CABINET and CHASSIS PARTS</b>		
11	SJF8709N	Terminal Board, Antenna, Output Socket, Power (1)
12 Except (XL)	SJS9225	Socket, Power (1)
13 (EX,EH)	SGP3212-2A	Rear Panel (1)
13 (XA)	SGP3212-4A	Rear Panel (1)
13 (XL)	SGP3212-5A	Rear Panel (1)
14	SJS9605	Socket (1)
15 (XL)	QFC1208M	Cord, Power Source (1)
15 (other)	SJA151	Cord, Power Source (1)
16	SHR127	Bushing (1)
17	SKCT8-SE	Cabinet (Silver) (1)
17	SKCT8-KE	Cabinet (Black) (1)
19	SHR301	Clamper, Lead Wire (1)
20	SJT347	Crip, Fuse (2)
21 Except (XL)	SMX663	Insulation Sheet, AC Socket (1)
22	SHR5269-1	Spacer (1)
<b>SCREWS and WASHERS</b>		
N1	XTB3+8BFZ	Tapping, $\text{\textcircled{3}}$ $\times$ 8 (2)
N2	XTB3+6BFN	Tapping, $\text{\textcircled{3}}$ $\times$ 6 (3)
N3	XTB3+8BFN	Tapping, $\text{\textcircled{3}}$ $\times$ 8 (2)
N4	XWE3D8	Washer, $\text{\textcircled{3}}$ (2)
N5	XTB3+8BFN	Tapping, $\text{\textcircled{3}}$ $\times$ 8 (4)
N6	XTB3+8BFN	Tapping, $\text{\textcircled{3}}$ $\times$ 8 (1)
N7	XTB3+8BFN	Tapping, $\text{\textcircled{3}}$ $\times$ 8 (3)
N8	XTB3+14BFN	Tapping, $\text{\textcircled{3}}$ $\times$ 14(1)
N9	XTB3+8BFN	Tapping, $\text{\textcircled{3}}$ $\times$ 8 (1)
N10	XWE3D8	Washer, $\text{\textcircled{3}}$ (1)
N11	XTB3+8BFZ	Tapping, $\text{\textcircled{3}}$ $\times$ 8 (2)
N12	XTB3+18BFZ	Tapping, $\text{\textcircled{3}}$ $\times$ 18(2)
N13	SNE2095-2	Screw, Cabinet (Silver) (4)
N13	SNE2095-3	Screw, Cabinet (Black) (4)

### EXPLODED VIEW

Ref. No.	Part No.	Part Name & Description
<b>PACKING PARTS</b>		
P1 (XL)	SPG4689	Carton Box (1)
P1 (other)	SPG4685	Carton Box (Silver) (1)
P1 (other)	SPG4691	Carton Box (Black) (1)
P2 (XL)	SPS3693-5	Pad, left (1)
P2 (other)	SPS3693-6	Pad, left (1)
P3 (XL)	SPS3695-5	Pad, Right (1)
P3 (other)	SPS3695-6	Pad, Right (1)
P4	SPS4377	Spacer (1)
P5	SPS4377	Pad, Front (1)
P6	SPP691-1	Polyethylene Sheet (Silver) (1)
P6	SPP713	Polyethylene Sheet (Black) (1)
P7 (XL) only	SGK1413	Label, Black (2)
<b>ACCESSORIES</b>		
A1 (XL)	SQF11905	Instruction Book (1)
A1 (other)	SQF11901	Instruction Book (1)
A2	SJP2241-1	Connection Cord (1)
A3	SSA267-1	FM Antenna (1)
A4	SSA611-1	Loop Antenna (1)
A5	SMA235-1	Holder, Loop Ant. (1)
A6	SMA233-1	Holder, Loop Ant. (1)
A7	XTN3+10AFZ	Screw (2)
A9 (XA) only	SJP5213-1	Plug Adaptor (1)
A10	SGE1689S	Bracket, Board (1)
A10	SGE1689B	Bracket, Board (1)
A11	SGET4-SE	Bracket Ass'y, Holder (Silver) (1)
A11	SGET4-KE	Bracket Ass'y, Holder (Black) (1)
A12	SGET4-SE1	Bracket Ass'y, Holder (Silver) (1)
A12	SGET4-KE1	Bracket Ass'y, Holder (Black) (1)

